

BIDDING DOCUMENT FOR

**Procurement of Automobile Tools and Equipment
(Lot 1-8) for Technical Training Institute Thimphu
(Serbithang) and Samthang.**

**Project Management Unit, Skills Training and Education
Pathways Upgradation Project (STEPUP)**

**Department of Workforce Planning and Skills Development
Ministry of Education and Skills Development**

Issued on: 13/04/2023

Invitation for Bids No.: (1564) DWPSD/STEPUP/G-13/2022-2023/

OCB (National) No.: 02

Purchaser: Project Management Unit, STEPUP, DWPSD, MoESD

Country: Bhutan

Preface

This Bidding Document for Procurement of Goods has been prepared by **Project Management Unit, Skills Training and Education Pathways Upgradation Project (STEPUP), Department of Workforce Planning and Skills Development (DWPSD), Ministry of Education and Skills Development (MoESD)** and is based on the Standard Bidding Document for the Procurement of Goods issued by the Asian Development Bank dated **December 2021**.

This document reflects the structure and the provisions of the Master Procurement Document for the Procurement of Goods, except where specific considerations within the Asian Development Bank have required a change.

Invitation for Bids

Date: **13/04/2023**

Grant No. and Title: **BHU G0596: Skills Training and Education Pathways Upgradation Project (STEP-UP)**

Contract No. and Title: **(1564) DWPSD/STEPUP/G-13/2022-2023/Procurement of Automobile Tools and Equipment (Lot 1-8)**

Deadline for Submission of Bids: **31/05/2023**

1. The Ministry of Education and Skills Development (MoESD) has received financing from the Asian Development Bank (ADB) toward the cost of Skills Training and Education Upgradation Project (STEPUP), and it intends to apply part of the proceeds of this financing to payments under the contract named above. Bidding is open to Bidders from eligible source countries of ADB.
2. The Project Management Unit, STEPUP, Department of Workforce Planning and Skills Development, MoESD ("the Purchaser") invites sealed bids from eligible Bidders for Procurement of Automobile Tools and Equipment (Lot 1-8).
3. Open competitive bidding will be conducted in accordance with ADB's Procurement Regulations for ADB Borrowers: Goods, Works, Nonconsulting and Consulting Services (2017) procedure and is open to all Bidders from eligible countries as described in the Bidding Document.
4. Only eligible Bidders with the following key qualifications defined in the Bidding Document may participate in this bidding:
 - Trade license
 - Tax clearance certificate
5. To obtain further information and inspect the Bidding Documents, Bidders should contact:

Tshewang Gyeltshen
Procurement Expert
Project Management Unit
Skills Training and Education Pathways Upgradation Project
Department of Workforce Planning and Skills Development
Ministry of Education and Skills Development (MoESD)
Email Id: gyeltshenpmu17@gmail.com

6. The tender document can be downloaded freely from the ministry's website <http://www.education.gov.bt/>
7. Deliver your bid:
 - to the address: **The Project Director, STEPUP, DWPSD, MoESD.**
 - on or before the deadline: **31/05/2023 on or before 2.30 PM.**
 - together with a Bid-Securing Declaration as described in the Bidding Document.

Bids will be opened promptly after the deadline for bid submission in the presence of Bidders' representatives who choose to attend.

8. When comparing Bids, Domestic Preference will **not be applied** as stipulated in the Bidding Document.

9. The Tender Document can be downloaded freely from the ministry's website <http://www.education.gov.bt/>

Yours Sincerely

Norbu Wangchuk

Project Director

Skills Training and Education Pathways Upgradation Project

Department of Workforce Planning and Skills Development

Ministry of Education and Skills Development (MoESD)

Table of Contents

PART I – Bidding Procedures

Section 1.	Instructions to Bidders	1-1
Section 2.	Bid Data Sheet	2-1
Section 3.	Evaluation and Qualification Criteria	3-1
Section 4.	Bidding Forms	4-1
Section 5.	Eligible Countries.....	5-1

PART II – Supply Requirements

Section 6.	Schedule of Supply.....	6-1
------------	-------------------------	-----

PART III – Conditions of Contract and Contract Forms

Section 7.	General Conditions of Contract	7-1
Section 8.	Special Conditions of Contract	8-1
Section 9.	Contract Forms.....	9-1

Section 1: Instructions to Bidders

Table of Contents

A.	General	1-11
1.	Scope of Bid	1-11
2.	Source of Funds	1-11
3.	Fraud and Corruption	1-11
4.	Eligible Bidders.....	1-6
5.	Eligible Goods and Related Services	1-15
B.	Contents of Bidding Document	1-16
6.	Sections of the Bidding Document	1-16
7.	Clarification of Bidding Document	1-8
8.	Amendment of Bidding Document.....	1-9
C.	Preparation of Bids	1-17
9.	Cost of Bidding	1-17
10.	Language of Bid	1-17
11.	Documents Comprising the Bid	1-17
12.	Bid Submission Sheet and Price Schedules	1-10
13.	Alternative Bids.....	1-10
14.	Bid Prices and Discounts.....	1-18
15.	Currencies of Bid	1-12
16.	Documents Establishing the Eligibility of the Bidder	1-12
17.	Documents Establishing the Eligibility of the Goods and Related Services.....	1-12
18.	Documents Establishing the Conformity of the Goods and Related Services to the Bidding Document	1-12
19.	Documents Establishing the Qualifications of the Bidder.....	1-12
20.	Period of Validity of Bids.....	1-13
21.	Bid Security/Bid-Securing Declaration	1-13
22.	Format and Signing of Bid.....	1-14
D.	Submission and Opening of Bids	1-15
23.	Sealing and Marking of Bids.....	1-15
24.	Deadline for Submission of Bids	1-15
25.	Late Bids.....	1-16
26.	Withdrawal, Substitution, and Modification of Bids	1-16
27.	Bid Opening.....	1-16
E.	Evaluation and Comparison of Bids	1-17
28.	Confidentiality	1-17
29.	Clarification of Bids.....	1-17
30.	Deviations, Reservations, and Omissions.....	1-18
31.	Determination of Responsiveness	1-18
32.	Nonmaterial Nonconformities	1-18
33.	Correction of Arithmetical Errors	1-19
34.	Conversion to Single Currency.....	1-19
35.	Domestic Preference	1-19
36.	Evaluation and Comparison of Bids	1-19
37.	Abnormally Low Bids	1-20
38.	Postqualification of the Bidder	1-21
39.	Purchaser's Right to Accept Any Bid, and to Reject Any or All Bids.....	1-21

40. Notice of Intention for Award of Contract 1-21

F. Award of Contract 1-21

41. Award Criteria 1-21

42. Purchaser's Right to Vary Quantities at Time of Award 1-22

43. Notification of Award..... 1-22

44. Signing of Contract 1-22

45. Performance Security 1-23

46. Bidding-Related Complaints 1-23

A. General

1. **Scope of Bid**
 - 1.1 In connection with the Invitation for Bids (IFB) indicated in the Bid Data Sheet (BDS), the Purchaser, as indicated in the BDS, issues this Bidding Document for the supply of Goods and Related Services incidental thereto as specified in Section 6 (Schedule of Supply). The name, identification, and number of lots of the open competitive bidding (OCB) are provided in the BDS.
 - 1.2 Throughout this Bidding Document,
 - (a) the term “in writing” means communicated in written form and delivered against receipt;
 - (b) except where the context requires otherwise, words indicating the singular also include the plural and words indicating the plural also include the singular; and
 - (c) “day” means calendar day.
2. **Source of Funds**
 - 2.1 The Borrower or Recipient (hereinafter called “Borrower”) indicated in the BDS has applied for or received financing (hereinafter called “funds”) from the Asian Development Bank (hereinafter called “ADB”) toward the cost of the project named in the BDS. The Borrower intends to apply a portion of the funds to eligible payments under the contract(s) for which this Bidding Document is issued.
 - 2.2 Payments by ADB will be made only at the request of the Borrower and upon approval by ADB in accordance with the terms and conditions of the Financing Agreement between the Borrower and ADB (hereinafter called the Financing Agreement), and will be subject in all respects to the terms and conditions of that Financing Agreement. No party other than the Borrower shall derive any rights from the Financing Agreement or have any claim to the funds.
3. **Fraud and Corruption**
 - 3.1 ADB requires Borrowers (including beneficiaries of ADB-financed activity) and their personnel, as well as firms and individuals participating in an ADB-financed activity, including but not limited to, Bidders, Suppliers, and Contractors, agents, subcontractors, subconsultants, service providers, subsuppliers, manufacturers (including their respective officers, directors, employees and personnel) under ADB-financed contracts to observe the highest standard of ethics during the procurement and execution of such contracts in accordance with ADB’s Anticorruption Policy (1998, as amended from time to time). In pursuance of this policy, ADB
 - (a) defines, for the purposes of this provision, the terms set forth below as follows:
 - (i) “corrupt practice” means the offering, giving, receiving, or soliciting, directly or indirectly, anything of value to influence improperly the actions of another party;
 - (ii) “fraudulent practice” means any act or omission, including a misrepresentation, that knowingly or recklessly misleads, or attempts to mislead, a party to obtain a financial or other benefit or to avoid an obligation;

- (iii) “coercive practice” means impairing or harming, or threatening to impair or harm, directly or indirectly, any party or the property of the party to influence improperly the actions of a party;
 - (iv) “collusive practice” means an arrangement between two or more parties designed to achieve an improper purpose, including influencing improperly the actions of another party;
 - (v) “abuse” means theft, waste, or improper use of assets related to ADB-related activity, either committed intentionally or through reckless disregard;
 - (vi) “conflict of interest” means any situation in which a party has interests that could improperly influence that party’s performance of official duties or responsibilities, contractual obligations, or compliance with applicable laws and regulations; and
 - (vii) “integrity violation” is any act, as defined under ADB’s Integrity Principles and Guidelines (2015, as amended from time to time), which violates ADB’s Anticorruption Policy, including (i) to (vi) above and the following: obstructive practice, violations of ADB sanctions, retaliation against whistleblowers or witnesses, and other violations of ADB’s Anticorruption Policy, including failure to adhere to the highest ethical standard.
- (b) will reject a proposal for award if it determines that the Bidder recommended for award or any of its officers, directors, employees, personnel, subconsultants, subcontractors, service providers, suppliers or manufacturers has, directly or through an agent, engaged in corrupt, fraudulent, collusive, coercive, or obstructive practices or other integrity violations in competing for the Contract;
 - (c) will cancel the portion of the financing allocated to a contract if it determines at any time that representatives of the Borrower or of a beneficiary of ADB-financing engaged in corrupt, fraudulent, collusive, coercive, or obstructive practices or other integrity violations during the procurement or the execution of that contract, without the Borrower having taken timely and appropriate action satisfactory to ADB to remedy the situation, including by failing to inform ADB in a timely manner at the time they knew of the integrity violations;
 - (d) will impose remedial actions on a firm or an individual, at any time, in accordance with ADB’s Anticorruption Policy and Integrity Principles and Guidelines, including declaring ineligible, either indefinitely or for a stated period of time, to participate in ADB-financed, -administered, or -supported activities or to benefit from an ADB-financed, -administered, or -supported contract, financially or otherwise, if it at any time determines that the firm or individual has, directly or through an agent, engaged in corrupt, fraudulent, collusive, coercive, or obstructive practices or other integrity violations; and
 - (e) will have the right to require that a provision be included in bidding documents and in contracts financed, administered, or supported by ADB, requiring Bidders, suppliers and contractors, consultants,

manufacturers, service providers and other third parties engaged or involved in ADB-related activities, and their respective officers, directors, employees and personnel, to permit ADB or its representative to inspect the site and their assets, accounts and records and other documents relating to the bid submission and contract performance and to have them audited by auditors appointed by ADB.

- 3.2 All Bidders, consultants, contractors, suppliers, manufacturers, service providers, and other third parties engaged or involved in ADB-related activities, and their respective officers, directors, employees and personnel, are obliged to cooperate fully in any investigation when requested by ADB to do so. As determined on a case by case basis by ADB, such cooperation includes, but is not limited to, the following:
- (a) being available to be interviewed and replying fully and truthfully to all questions asked;
 - (b) providing ADB with any items requested that are within the party's control including, but not limited to, documents and other physical objects;
 - (c) upon written request by ADB, authorizing other related entities to release directly to ADB such information that is specifically and materially related, directly or indirectly, to the said entities or issues which are the subject of the investigation;
 - (d) cooperating with all reasonable requests to search or physically inspect their person and/or work areas, including files, electronic databases, and personal property used on ADB activities, or that utilizes ADB's Information and Communication Technology (ICT) resources or systems (including mobile phones, personal electronic devices, and electronic storage devices such as external disk drives);
 - (e) cooperating in any testing requested by ADB, including but not limited to, fingerprint identification, handwriting analysis, and physical examination and analysis; and
 - (f) preserving and protecting confidentiality of all information discussed with, and as required by, ADB.
- 3.3 All Bidders, consultants, contractors and suppliers shall require their officers, directors, employees, personnel, agents to ensure that, in its contracts with its subconsultants, Subcontractors and other third parties engaged or involved in ADB-related activities, such subconsultants, Subcontractors and other third parties similarly are obliged to cooperate fully in any investigation when requested by ADB to do so.
- 3.4 The Purchaser hereby puts the Bidder on notice that the Bidder or any Joint Venture partner of the Bidder (if any) may not be able to receive any payments under the Contract if the Bidder or any of its Joint Venture partners, as appropriate, is, or is owned (in whole or in part) by a person or entity subject to applicable sanctions.
- 3.5 Furthermore, Bidders shall be aware of the provision stated in Subclause 3.2 and Subclause 35.1 (a)(iii) of the General Conditions of Contract.

4. Eligible Bidders

- 4.1 A Bidder may be a natural person, private entity, or government-owned enterprise subject to ITB 4.5-or any combination of them with a formal

intent to enter into an agreement or under an existing agreement in the form of a Joint Venture. In the case of a Joint Venture,

- (a) all parties to the Joint Venture shall be jointly and severally liable; and
- (b) the Joint Venture shall nominate a representative who shall have the authority to conduct all businesses for and on behalf of any and all the parties of the Joint Venture during the bidding process and, in the event the Joint Venture is awarded the Contract, during contract execution.

4.2 A Bidder, and all parties constituting the Bidder, shall have the nationality of an eligible country, in accordance with Section 5 (Eligible Countries). A Bidder shall be deemed to have the nationality of a country if the Bidder is a citizen or is constituted, incorporated, or registered, and operates in conformity with the provisions of the laws of that country. This criterion shall also apply to the determination of the nationality of proposed subcontractors or suppliers for any part of the Contract, including related services.

4.3 A Bidder shall not have a conflict of interest. All Bidders found to have a conflict of interest shall be disqualified. A Bidder may be considered to be in a conflict of interest with one or more parties in this bidding process if any of, including but not limited to, the following apply:

- (a) they have controlling shareholders in common; or
- (b) they receive or have received any direct or indirect subsidy from any of them; or
- (c) they have the same legal representative for purposes of this Bid; or
- (d) they have a relationship with each other, directly or through common third parties, that puts them in a position to have access to material information about or improperly influence the Bid of another Bidder, or influence the decisions of the Purchaser regarding this bidding process; or
- (e) a Bidder participates in more than one bid in this bidding process, either individually or as a partner in a Joint Venture, except for alternative offers permitted under ITB 13. This will result in the disqualification of all Bids in which it is involved. However, subject to any finding of a conflict of interest in terms of ITB 4.3(a)–(d) above, this does not limit the participation of a Bidder as a subcontractor in another bid or of a firm as a subcontractor in more than one Bid; or
- (f) a Bidder, Joint Venture partner, associates, parent company or any affiliated entity, participated as a consultant in the preparation of the design or technical specifications of the goods and services that are the subject of the Bid; or

- (g) a Bidder was affiliated with a firm or entity that has been hired (or is proposed to be hired) by the Purchaser or Borrower as Project Manager for the contract; or
- (h) a Bidder would be providing goods, works, or nonconsulting services resulting from or directly related to consulting services for the preparation or implementation of the project specified in the BDS ITB 2.1 that it provided or were provided by any affiliate that directly or indirectly controls, is controlled by, or is under common control with that firm; or
- (i) A Bidder that has a financial or familial relationship with staff of the Purchaser including project implementing/executing agency, or of a recipient of a part of the loan who: (i) are directly or indirectly involved in the preparation of the bidding documents or specifications of the contract, and/or the bid evaluation process of such contract; or (ii) would be involved in the implementation or supervision of such contract unless the conflict stemming from such relationship has been resolved in a manner acceptable to ADB throughout the procurement process and execution of the contract.

- 4.4 A firm will not be eligible to participate in any procurement activities under an ADB-financed, -administered, or -supported project while under temporary suspension or debarment by ADB pursuant to its Anticorruption Policy (see ITB 3), whether such debarment was directly imposed by ADB, or enforced by ADB pursuant to the Agreement for Mutual Enforcement of Debarment Decisions. A bid from a temporarily suspended or debarred firm will be rejected and such bid may be in breach of debarment conditions, thereby subject to further ADB's investigation.
- 4.5 Government-owned enterprises in the Purchaser's country shall be eligible only if they can establish that they (i) are legally and financially autonomous, (ii) operate under commercial law, and (iii) are not dependent agencies of the Purchaser.
- 4.6 A Bidder shall not be under suspension from Bidding by the Purchaser as a result of the execution of a Bid-Securing Declaration.
- 4.7 Bidders shall provide such evidence of their continued eligibility satisfactory to the Purchaser, as the Purchaser shall reasonably request.
- 4.8 Bidders shall be excluded if, by an act of compliance with a decision of the United Nations Security Council taken under Chapter VII of the Charter of the United Nations, the Borrower's country prohibits any import of goods from, or payments to, a particular country, person or entity in respect of goods or services originating in that country. Where the Borrower's country prohibits payments to a particular person or entity or for particular goods or services by such an act of compliance, that firm shall be excluded.

5. Eligible Goods and Related Services

- 5.1 All Goods and Related Services to be supplied under the Contract and financed by ADB, shall have their country of origin in eligible source countries as defined in ITB 4.2, and all expenditures under the Contract will be limited to such Goods and Related Services.

- 5.2 For purposes of this clause, the term “goods” includes commodities, raw material, machinery, equipment, and industrial plants; and “related services” includes services such as insurance, transportation, installation, commissioning, training, and initial maintenance.
- 5.3 The term “country of origin” means the country where the goods have been mined, grown, cultivated, produced, manufactured, or processed; or through manufacture, processing, or assembly, another commercially recognized article results that differs substantially in its basic characteristics from its imported components.
- 5.4 The nationality of the firm that produces, assembles, distributes, or sells the goods shall not determine their origin.

B. Contents of Bidding Document

6. **Sections of the Bidding Document** 6.1 The Bidding Document consists of Parts I, II, and III, which include all the sections indicated below, and should be read in conjunction with any addenda issued in accordance with ITB 8.

PART I Bidding Procedures

- Section 1 Instructions to Bidders (ITB)
- Section 2 Bid Data Sheet (BDS)
- Section 3 Evaluation and Qualification Criteria (EQC)
- Section 4 Bidding Forms (BDF)
- Section 5 Eligible Countries (ELC)

PART II Supply Requirements

- Section 6 Schedule of Supply (SS)

PART III Conditions of Contract and Contract Forms

- Section 7 General Conditions of Contract (GCC)
- Section 8 Special Conditions of Contract (SCC)
- Section 9 Contract Forms (COF)

- 6.2 The IFB issued by the Purchaser is not part of the Bidding Document.
- 6.3 The Purchaser is not responsible for the completeness of the Bidding Document and its addenda, if they were not obtained directly from the source stated by the Purchaser in the IFB.
- 6.4 The Bidder is expected to examine all instructions, forms, terms, and specifications in the Bidding Document. Failure to furnish all information or documentation required by the Bidding Document, may result in the rejection of the Bid.
7. **Clarification of Bidding Document** 7.1 A prospective Bidder requiring any clarification on the Bidding Document shall contact the Purchaser in writing at the Purchaser’s address indicated in the BDS. The Purchaser will respond in writing to any request for clarification, provided that such request is received no later than 21 days prior to the deadline for submission of Bids. The Purchaser shall forward copies of its response to all Bidders who have acquired the Bidding Document in accordance with ITB 6.3, including a description of the inquiry but without identifying its source. Should the

Purchaser deem it necessary to amend the Bidding Document as a result of a clarification, it shall do so following the procedure under ITB 8 and ITB 24.2.

- 8. Amendment of Bidding Document**
- 8.1 At any time prior to the deadline for submission of the Bids, the Purchaser may amend the Bidding Document by issuing addenda.
- 8.2 Any addendum issued shall be part of the Bidding Document and shall be communicated in writing to all who have obtained the Bidding Document directly from the Purchaser in accordance with ITB 6.3.
- 8.3 To give prospective Bidders reasonable time in which to take an addendum into account in preparing their Bids, the Purchaser may, at its discretion, extend the deadline for the submission of the Bids, pursuant to ITB 24.2.

C. Preparation of Bids

- 9. Cost of Bidding** 9.1 The Bidder shall bear all costs associated with the preparation and submission of its Bid, and the Purchaser shall in no case be responsible or liable for those costs, regardless of the conduct or outcome of the bidding process.
- 10. Language of Bid** 10.1 The Bid, as well as all correspondence and documents relating to the Bid exchanged by the Bidder and the Purchaser, shall be written in the language specified in the BDS. Supporting documents and printed literature that are part of the Bid may be in another language provided they are accompanied by an accurate translation of the relevant passages in the language specified in the BDS, in which case, for purposes of interpretation of the Bid, such translation shall govern.
- 11. Documents Comprising the Bid** 11.1 The Bid shall comprise the following:
- (a) Bid Submission Sheet and the applicable Price Schedules, in accordance with ITB 12, ITB 14, and ITB 15;
 - (b) Bid Security or Bid-Securing Declaration, in accordance with ITB 21;
 - (c) alternative Bids, if permissible, in accordance with ITB 13;
 - (d) written confirmation authorizing the signatory of the Bid to commit the Bidder, in accordance with ITB 22;
 - (e) documentary evidence in accordance with ITB 16, establishing the Bidder's eligibility to bid;
 - (f) documentary evidence in accordance with ITB 17, that the Goods and Related Services to be supplied by the Bidder are of eligible origin;
 - (g) documentary evidence in accordance with ITB 18 and ITB 31, that the Goods and Related Services conform to the Bidding Document;
 - (h) documentary evidence in accordance with ITB 19, establishing the Bidder's qualifications to perform the contract if its Bid is accepted; and
 - (i) any other document required in the BDS.

- 12. Bid Submission Sheet and Price Schedules**
- 12.1 The Bidder shall submit the Bid Submission Sheet using the form furnished in Section 4 (Bidding Forms). This form must be completed without any alterations to its format, and no substitutes shall be accepted. All blank spaces shall be filled in with the information requested.
- 12.2 The Bidder shall submit the Price Schedules for Goods and Related Services, according to their origin as appropriate, using the forms furnished in Section 4 (Bidding Forms) and as required in the BDS.
- 13. Alternative Bids**
- 13.1 Unless otherwise indicated in the BDS, alternative Bids shall not be considered.
- 14. Bid Prices and Discounts**
- 14.1 The prices and discounts quoted by the Bidder in the Bid Submission Sheet and in the Price Schedules shall conform to the requirements specified below.
- 14.2 All items in the Schedule of Supply must be listed and priced separately in the Price Schedules. If a Price Schedule shows items listed but not priced, their prices shall be assumed to be included in the prices of other items. Items not listed in the Price Schedule shall be assumed not to be included in the Bid, and provided that the Bid is substantially responsive, the corresponding adjustment shall be applied in accordance with ITB 32.3. Unit rates and prices for all items in the Schedule of Supply shall be expressed in positive values. If unit rates and prices are expressed in negative values, the bid will be rejected.
- 14.3 The price to be quoted in the Bid Submission Sheet shall be the total price of the Bid excluding any discounts offered. Absence of the total bid price in the Bid Submission Sheet may result in the rejection of the Bid.
- 14.4 The Bidder shall quote discounts and the methodology for their application in the Bid Submission Sheet.
- 14.5 The terms EXW, CIF, CIP, and other similar terms shall be governed by the rules prescribed in the current edition of Incoterms, published by the International Chamber of Commerce, at the date of the Invitation for Bids or as specified in the BDS.
- 14.6 Prices shall be quoted as specified in each Price Schedule included in Section 4 (Bidding Forms). The disaggregation of price components is required solely for the purpose of facilitating the comparison of Bids by the Purchaser. This shall not in any way limit the Purchaser's right to contract on any of the terms offered
- (a) for Goods offered from within the Purchaser's country:
- (i) the price of the goods quoted EXW (ex works, ex factory, ex warehouse, ex showroom, or off-the-shelf, as applicable), including all customs duties and sales and other taxes already paid or payable on the components and raw material used in the manufacture or assembly of goods quoted ex works or ex factory, or on the previously

- imported goods of foreign origin quoted ex warehouse, ex showroom, or off-the-shelf;
 - (ii) sales tax and all other taxes applicable in the Purchaser's country and payable on the Goods if the Contract is awarded to the Bidder; and
 - (iii) the total price for the item.
- (b) for Goods offered from outside the Purchaser's country:
- (i) the price of the goods quoted CIF (named port of destination), or CIP (border point), or CIP (named place of destination), in the Purchaser's country, as specified in the BDS;
 - (ii) the price of the goods quoted FOB port of shipment (or FCA, as the case may be), if specified in the BDS; and
 - (iii) the total price for the item.
- (c) for Related Services whenever such are specified in the Schedule of Supply:
- (i) the local currency cost component of each item comprising the Related Services; and
 - (ii) the foreign currency cost component of each item comprising the Related Services, inclusive of all customs duties, sales and other similar taxes applicable in the Purchaser's country, payable on the Related Services, if the Contract is awarded to the Bidder.
- 14.7 Prices quoted by the Bidder shall be fixed during the Bidder's performance of the Contract and not subject to variation on any account, unless otherwise specified in the BDS. A Bid submitted with an adjustable price quotation shall be treated as nonresponsive and shall be rejected, pursuant to ITB 31. If in accordance with the BDS, prices quoted by the Bidder shall be subject to adjustment during the performance of the Contract in accordance with Clause 15.2 of the General Conditions of Contract in Section 7, a Bid submitted with a fixed price will also be treated as nonresponsive and be rejected.
- 14.8 If so indicated pursuant to ITB 1.1, Bids are being invited for individual contracts (lots) or for any combination of contracts (packages). Unless otherwise indicated in the BDS, prices quoted shall correspond to 100% of the items specified for each lot and to 100% of the quantities specified for each item of a lot. Bidders wishing to offer any price discount for the award of more than one Contract shall specify in their bid the price discount applicable to each package, or alternatively, to individual Contracts within the package. Price discounts shall be submitted in accordance with ITB 14.4, provided the bids for all lots are submitted and opened at the same time.

15. Currencies of Bid

15.1 Bid prices shall be quoted in the following currencies:

- (a) Bidders may express their bid price in any freely convertible currency. If a Bidder wishes to be paid in a combination of

amounts in different currencies, it may quote its price accordingly.

- (b) If some of the expenditures for the Related Services are to be incurred in the borrowing country, such expenditures should be expressed in the Bid and will be payable in the Purchaser's currency.

- | | |
|--|--|
| 16. Documents Establishing the Eligibility of the Bidder | <p>16.1 To establish their eligibility in accordance with ITB 4, Bidders shall</p> <ul style="list-style-type: none"> (a) complete the eligibility declarations in the Bid Submission Sheet, included in Section 4 (Bidding Forms); and (b) if the Bidder is an existing or intended Joint Venture in accordance with ITB 4.1, submit a copy of the Joint Venture Agreement, or a letter of intent to enter into such an agreement. The respective document shall be signed by all legally authorized signatories of all the parties to the existing or intended Joint Venture, as appropriate. |
| 17. Documents Establishing the Eligibility of the Goods and Related Services | <p>17.1 To establish the eligibility of the Goods and Related Services, in accordance with ITB 5, Bidders shall complete the country of origin declarations in the Price Schedule Forms included in Section 4 (Bidding Forms).</p> |
| 18. Documents Establishing the Conformity of the Goods and Related Services to the Bidding Document | <p>18.1 To establish the conformity of the Goods and Related Services to the Bidding Document, the Bidder shall furnish as part of its Bid documentary evidence that the Goods and Related Services conform to the requirements specified in Section 6 (Supply of Supply).</p> <p>18.2 The documentary evidence may be in the form of literature, drawings, or data, and shall consist of a detailed item-by-item description of the essential technical and performance characteristics of the Goods and Related Services, demonstrating substantial responsiveness of the Goods and Related Services to those requirements, and if applicable, a statement of deviations and exceptions to the provisions of Section 6 (Schedule of Supply).</p> <p>18.3 Standards for workmanship, process, material, and equipment, as well as references to brand names or catalogue numbers specified by the Purchaser in Section 6 (Schedule of Supply), are intended to be descriptive only and not restrictive. The Bidder may offer other standards of quality, brand names, and/or catalogue numbers, provided that it demonstrates, to the Purchaser's satisfaction, that the substitutions ensure substantial equivalence or are superior to those specified in Section 6 (Schedule of Supply).</p> |
| 19. Documents Establishing the Qualifications of the Bidder | <p>19.1 The documentary evidence of the Bidder's qualifications to perform the contract, if its bid is accepted, shall establish to the Purchaser's satisfaction that the Bidder meets each of the qualification criterion specified in Section 3 (Evaluation and Qualification Criteria).</p> <p>19.2 If so required in the BDS, a Bidder that does not manufacture or produce the Goods it offers to supply shall submit the Manufacturer's Authorization using the form included in Section 4 (Bidding Forms) to</p> |

demonstrate that it has been duly authorized by the manufacturer or producer of the Goods to supply these Goods in the Purchaser's country.

- 19.3 If so required in the BDS, a Bidder that does not conduct business within the Purchaser's country shall submit evidence that it will be represented by an agent in the country equipped and able to carry out the Supplier's maintenance, repair, and spare parts-stocking obligations prescribed in the Conditions of Contract and/or Technical Specifications.
- 20. Period of Validity of Bids**
- 20.1 Bids shall remain valid for the bid validity period specified in the BDS. The bid validity period starts from the date fixed for the bid submission deadline date prescribed by the Purchaser in accordance with ITB 24.1. A Bid valid for a shorter period shall be rejected by the Purchaser as nonresponsive.
- 20.2 In exceptional circumstances, prior to the expiration of the bid validity period, the Purchaser may request Bidders to extend the period of validity of their Bids. The request and the responses shall be made in writing. If a Bid Security is requested in accordance with ITB 21, it shall also be extended 28 days beyond the deadline of the extended bid validity period. A Bidder may refuse the request without forfeiting its Bid Security. A Bidder granting the request shall not be required or permitted to modify its Bid.
- 21. Bid Security/ Bid-Securing Declaration**
- 21.1 Unless otherwise specified in the BDS, the Bidder shall furnish as part of its Bid, in original form, either a Bid-Securing Declaration or a bid security as specified in the BDS. In the case of a bid security, the amount and currency shall be as specified in the BDS.
- 21.2 If a Bid-Securing Declaration is required pursuant to ITB 21.1, it shall use the form included in Section 4 (Bidding Forms). The Purchaser will declare a Bidder ineligible to be awarded a Contract for a specified period of time, as indicated in the BDS, if a Bid-Securing Declaration is executed.
- 21.3 If a bid security is specified pursuant to ITB 21.1, the bid security shall be, at the Bidder's option, in any of the following forms:
- (a) an unconditional bank guarantee (hard copy of the bank guarantee or in the form of SWIFT message MT760), or
 - (b) an irrevocable letter of credit, or
 - (c) a cashier's or certified check.
- all from a reputable source from an eligible country as described in Section 5 (Eligible Countries). In the case of a bank guarantee, the bid security shall be submitted either using the Bid Security Form included in Section 4 (Bidding Forms), or another form acceptable to the Purchaser. The form must include the complete name of the Bidder. The bid security shall be valid for 28 days beyond the original validity period of the bid, or beyond any period of extension if requested under ITB 20.2.

- 21.4 Unless otherwise specified in the BDS, any bid not accompanied by a substantially compliant bid security or Bid-Securing Declaration, if one is required in accordance with ITB 21.1, shall be rejected by the Purchaser as nonresponsive.
- 21.5 If a bid security is specified pursuant to ITB 21.1, the bid security of unsuccessful Bidders shall be returned promptly upon the successful Bidder's furnishing of the performance security pursuant to ITB 45.
- 21.6 If a bid security is specified pursuant to ITB 21.1, the bid security of the successful Bidder shall be returned promptly once the successful Bidder has signed the Contract Agreement and furnished the required performance security.
- 21.7 The bid security may be forfeited or the Bid-Securing Declaration executed, if
- (a) notwithstanding ITB 26.3, a Bidder withdraws its bid during the period of bid validity specified by the Bidder on the Bid Submission Sheet, except as provided in ITB 20.2; or
 - (b) the successful Bidder fails to
 - (i) sign the Contract Agreement in accordance with ITB 44;
 - (ii) furnish a performance security in accordance with ITB 45; or
 - (iii) accept the arithmetical corrections of its bid in accordance with ITB 33.
- 21.8 If the bid security is required as per ITB 21.1, the bid security of a Joint Venture shall be in the name of the Joint Venture that submits the Bid. If the Joint Venture has not been legally constituted at the time of bidding, the bid security shall be in the name of any or all of the Joint Venture partners. If the Bid-Securing Declaration is required as per ITB 21.1, the Bid-Securing Declaration of a Joint Venture shall be in the name of the Joint Venture that submits the Bid. If the Joint Venture has not been legally constituted at the time of bidding, the Bid-Securing Declaration shall be in the names of all future partners as named in the letter of intent mentioned in ITB 4.1.

22. Format and Signing of Bid

- 22.1 The Bidder shall prepare one original set of the documents comprising the Bid as described in ITB 11 and clearly mark it "ORIGINAL." Alternative bids, if permitted in accordance with ITB 13, shall be clearly marked "ALTERNATIVE". In addition, the Bidder shall submit copies of the bid, in the number specified in the BDS and clearly mark them "COPY." In the event of any discrepancy between the original and the copies, the original shall prevail.
- 22.2 The original and all copies of the Bid shall be typed or written in indelible ink and shall be signed by a person duly authorized to sign on behalf of the Bidder. This authorization shall consist of a written confirmation as specified in the BDS and shall be attached to the Bid. The name and position held by each person signing the authorization must be typed or printed below the signature. If a Bidder submits a deficient authorization, the Bid shall not be rejected in the first instance. The Purchaser shall request the Bidder to submit an acceptable authorization within the number of days as specified in the BDS. Failure

to provide an acceptable authorization within the period stated in the Purchaser's request shall cause the rejection of the Bid. If either the Bid Submission Sheet or the Bid-Securing Declaration (if applicable) is not signed, the Bid shall be rejected.

- 22.3 Any amendments such as interlineations, erasures, or overwriting shall be valid only if they are signed or initialed by the person signing the bid.

D. Submission and Opening of Bids

- 23. Sealing and Marking of Bids**
- 23.1 Bidders shall submit their Bids as specified in the BDS. Procedures for submission, sealing and marking are as follows:
- (a) Bidders submitting Bids by mail or by hand shall enclose the original and each copy of the Bid, including alternative Bids, if permitted in accordance with ITB 13, in separate sealed envelopes, duly marking the envelopes as "ORIGINAL", "ALTERNATIVE" and "COPY." These envelopes containing the original and the copies shall then be enclosed in one single envelope. The rest of the procedure shall be in accordance with ITB 23.2 and ITB 23.3.
 - (b) Bidders submitting Bids electronically shall follow the electronic bid submission procedures specified in the BDS.
- 23.2 The inner and outer envelopes shall
- (a) bear the name and address of the Bidder;
 - (b) be addressed to the Purchaser in accordance with ITB 24.1;
 - (c) bear the specific identification of this bidding process pursuant to ITB 1.1 and any additional identification marks as specified in the BDS; and
 - (d) bear a warning not to open before the time and date for bid opening, in accordance with ITB 27.1.
- 23.3 If all envelopes are not sealed and marked as required, the Purchaser will assume no responsibility for the misplacement or premature opening of the Bid.
- 24. Deadline for Submission of Bids**
- 24.1 Bids must be received by the Purchaser at the address and no later than the date and time indicated in the BDS.
- 24.2 The Purchaser may, at its discretion, extend the deadline for the submission of Bids by amending the Bidding Document in accordance with ITB 8, in which case all rights and obligations of the Purchaser and Bidders previously subject to the deadline shall thereafter be subject to the deadline as extended.
- 25. Late Bids**
- 25.1 The Purchaser shall not consider any Bid that arrives after the deadline for submission of Bids, in accordance with ITB 24. Any Bid received by the Purchaser after the deadline for submission of Bids shall be declared late, rejected, and returned unopened to the Bidder.

- 26. Withdrawal, Substitution, and Modification of Bids**
- 26.1 A Bidder may withdraw, substitute, or modify its Bid after it has been submitted by sending a written notice, duly signed by an authorized representative, and shall include a copy of the authorization in accordance with ITB 22.2 (except for withdrawal notices, which do not require copies). The corresponding substitution or modification of the bid must accompany the respective written notice. All notices must be
- (a) prepared and submitted in accordance with ITB 22 and ITB 23 (except for withdrawal notices, which do not require copies), and in addition, the respective envelopes shall be clearly marked "WITHDRAWAL," "SUBSTITUTION," "MODIFICATION," and
 - (b) received by the Purchaser prior to the deadline prescribed for submission of bids, in accordance with ITB 24.
- 26.2 Bids requested to be withdrawn in accordance with ITB 26.1 shall be returned unopened to the Bidders.
- 26.3 No Bid may be withdrawn, substituted, or modified in the interval between the deadline for submission of bids and the expiration of the period of bid validity specified by the Bidder on the Bid Submission Sheet or any extension thereof.
- 27. Bid Opening**
- 27.1 The Purchaser shall open the Bids in public at the address, on the date, and time specified in the BDS in the presence of Bidders` designated representatives and anyone who chooses to attend. Any specific electronic bid opening procedures required if electronic bidding is permitted in accordance with ITB 23.1, shall be as specified in the BDS.
- 27.2 First, envelopes marked "WITHDRAWAL" shall be opened, read out, and recorded, and the envelope containing the corresponding bid shall not be opened, but returned to the Bidder. No bid withdrawal shall be permitted unless the corresponding withdrawal notice contains a valid authorization to request the withdrawal and is read out at bid opening. Next, envelopes marked "SUBSTITUTION" shall be opened, read out, recorded, and exchanged for the corresponding Bid being substituted. The substituted Bid shall not be opened, but returned unopened to the Bidder. No bid substitution shall be permitted unless the corresponding substitution notice contains a valid authorization to request the substitution and is read out and recorded at bid opening. Envelopes marked "MODIFICATION" shall be opened, read out, and recorded with the corresponding Bid. No bid modification shall be permitted unless the corresponding modification notice contains a valid authorization to request the modification and is read out and recorded at bid opening. Only envelopes that are opened, read out, and recorded at bid opening shall be considered further.
- 27.3 All other envelopes shall be opened one at a time, reading out the name of the Bidder and whether there is a modification; the Bid Prices (per lot if applicable), discounts, and alternative offers; the presence of a bid security or a Bid-Securing Declaration, if required; and any other details as the Purchaser may consider appropriate. Only discounts and alternative offers read out and recorded at bid opening shall be considered for evaluation. Unless otherwise specified in the BDS, all pages of the Bid Submission Sheet and Price Schedules are to be initialed by at least three representatives of the Purchaser attending

the bid opening. No Bid shall be rejected at bid opening except for late bids, in accordance with ITB 25.1.

- 27.4 The Purchaser shall prepare a record of the bid opening that shall include, as a minimum: the name of the Bidder and whether there is a withdrawal, substitution, or modification; the Bid Price, per lot if applicable, any discounts, and alternative offers if they were permitted; and the presence or absence of a bid security or Bid-Securing Declaration, if one was required. The Bidders' representatives who are present shall be requested to sign the record. The omission of a Bidder's signature on the record shall not invalidate the contents and effect of the record. A copy of the record shall be distributed to all Bidders who submitted bids on time, and posted online if electronic bidding was permitted.

E. Evaluation and Comparison of Bids

- 28. Confidentiality**
- 28.1 Information relating to the examination, evaluation, comparison, and postqualification of Bids, and recommendation of contract award, shall not be disclosed to Bidders or any other persons not officially concerned with such process until the publication of Contract award.
- 28.2 Any attempt by a Bidder to influence the Purchaser in the examination, evaluation, comparison, and postqualification of the Bids or Contract award decisions may result in the rejection of its Bid.
- 28.3 Notwithstanding ITB 28.2, from the time of bid opening to the time of Contract award, if any Bidder wishes to contact the Purchaser on any matter related to the bidding process, it should do so in writing.
- 29. Clarification of Bids**
- 29.1 To assist in the examination, evaluation, comparison and post-qualification of the Bids, the Purchaser may, at its discretion, ask any Bidder for a clarification of its Bid. Any clarification submitted by a Bidder with regard to its Bid and that is not in response to a request by the Purchaser shall not be considered. The Purchaser's request for clarification and the response shall be in writing. No change in the prices or substance of the Bid shall be sought, offered, or permitted, except to confirm the correction of arithmetic errors discovered by the Purchaser in the evaluation of the Bids, in accordance with ITB 33.
- 29.2 If a Bidder does not provide clarifications on its Bid by the date and time set in the Purchaser's request for clarification, its bid may be rejected.
- 30. Deviations, Reservations, and Omissions**
- 30.1 During the evaluation of Bids, the following definitions apply:
- (a) "Deviation" is a departure from the requirements specified in the Bidding Document;
 - (b) "Reservation" is the setting of limiting conditions or withholding from complete acceptance of the requirements specified in the Bidding Document; and
 - (c) "Omission" is the failure to submit part or all of the information or documentation required in the Bidding Document.

- 31. Determination of Responsiveness**
- 31.1 The Purchaser's determination of a bid's responsiveness is to be based on the contents of the bid itself, as defined in ITB 11.
- 31.2 A substantially responsive bid is one that meets the requirements of the Bidding Document without material deviation, reservation, or omission. A material deviation, reservation, or omission is one that,
- (a) if accepted, would
 - (i) affect in any substantial way the scope, quality, or performance of the Goods and Related Services specified in Section 6 (Schedule of Supply); or
 - (ii) limits in any substantial way, inconsistent with the Bidding Document, the Purchaser's rights or the Bidder's obligations under the proposed Contract; or
 - (b) if rectified, would unfairly affect the competitive position of other Bidders presenting substantially responsive bids.
- 31.3 The Purchaser shall examine the technical aspects of the Bid in particular, to confirm that all requirements of Section 6 (Schedule of Supply) have been met without any material deviation, reservation, or omission.
- 31.4 If a Bid is not substantially responsive to the requirements of the Bidding Document, it shall be rejected by the Purchaser and may not subsequently be made responsive by correction of the material deviation, reservation, or omission.
- 32. Nonmaterial Nonconformities**
- 32.1 Provided that a Bid is substantially responsive, the Purchaser may waive nonconformities in the bid that do not constitute a material deviation, reservation, or omission.
- 32.2 Provided that a Bid is substantially responsive, the Purchaser may request that the Bidder submit the necessary information or documentation, within a reasonable period of time, to rectify nonmaterial nonconformities or omissions in the Bid related to documentation requirements. Requesting information or documentation on such nonconformities shall not be related to any aspect of the price of the Bid. Failure of the Bidder to comply with the request may result in the rejection of its Bid.
- 32.3 Provided that a Bid is substantially responsive, the Purchaser shall rectify quantifiable nonmaterial nonconformities or omissions related to the Bid Price. To this effect, the Bid Price shall be adjusted, for comparison purposes only, to reflect the price of the missing or non-conforming item or component. The adjustment shall be made using the method indicated in Section 3 (Evaluation and Qualification Criteria).
- 33. Correction of Arithmetical Errors**
- 33.1 Provided that the Bid is substantially responsive, the Purchaser shall correct arithmetical errors on the following basis:
- (a) If there is a discrepancy between the unit price and the total price that is obtained by multiplying the unit price and quantity, the unit price shall prevail and the total price shall be corrected, unless in the opinion of the Purchaser there is an obvious misplacement of the decimal point in the unit price, in which

case the total price as quoted shall govern and the unit price shall be corrected.

- (b) If there is an error in a total corresponding to the addition or subtraction of subtotals, the subtotals shall prevail and the total shall be corrected.
- (c) If there is a discrepancy between words and figures, the amount in words shall prevail, unless the amount expressed in words is related to an arithmetic error, in which case the amount in figures shall prevail subject to (a) and (b) above.

33.2 If the Bidder that submitted the lowest evaluated Bid does not accept the correction of errors, its Bid shall be rejected, and its bid security may be forfeited, or its Bid-Securing Declaration executed.

34. Conversion to Single Currency

34.1 For evaluation and comparison purposes, the currency(ies) of the Bid shall be converted into a single currency as specified in the BDS.

35. Domestic Preference

35.1 Unless otherwise specified in the BDS, domestic preference shall not apply.

36. Evaluation and Comparison of Bids

36.1 The Purchaser shall use the criteria and methodologies indicated in this clause. No other criteria or methodologies shall be permitted.

36.2 To evaluate a Bid, the Purchaser shall consider the following:

- (a) the bid price as quoted in accordance with ITB 14;
- (b) price adjustment for correction of arithmetic errors in accordance with ITB 33.1;
- (c) price adjustment due to discounts offered in accordance with ITB 14.4;
- (d) adjustment for nonmaterial nonconformities in accordance with ITB 32.3;
- (e) assessment whether the bid is abnormally low in accordance with ITB 37; and
- (f) price adjustment due to application of the evaluation criteria specified in Section 3 (Evaluation and Qualification Criteria). These criteria may include factors related to the characteristics, performance, and terms and conditions of purchase of the Goods and Related Services which shall be expressed to the extent practicable in monetary terms to facilitate comparison of bids unless otherwise specified in Section 3; and
- (g) converting the amount resulting from applying (a) to (c) above, if relevant, to a single currency in accordance with ITB 34.

36.3 The Purchaser's evaluation of a bid will exclude and not take into account,

- (a) in the case of Goods offered from within the Purchaser's country, all sales tax and all other taxes, applicable in the Purchaser's country and payable on the Goods if the Contract is awarded to the Bidder;
 - (b) in the case of Goods offered from outside the Purchaser's country, all customs duties, sales tax, and other taxes, applicable in the Purchaser's country and payable on the Goods if the Contract is awarded to the Bidder; and
 - (c) any allowance for price adjustment during the period of performance of the Contract, if provided in the Bid.
- 36.4 If the Bidding Document allows Bidders to quote separate prices for different lots (contracts), and the award to a single Bidder of multiple lots (contracts), the methodology to determine the lowest evaluated price of the lot (contract) combinations, including any discounts offered in the Bid Submission Sheet, is specified in Section 3 (Evaluation and Qualification Criteria).
- 36.5 The Purchaser shall compare all substantially responsive Bids to determine the lowest evaluated bid, in accordance with ITB 36.2.
- 37. Abnormally Low Bids**
- 37.1 An abnormally low bid is one where the bid price, in combination with other elements of the bid, appears to be so low that it raises concerns as to the capability of the Bidder to perform the contract for the offered bid price.
- 37.2 When the offered bid price appears to be abnormally low, the Purchaser shall undertake a three-step review process as follows:
- (a) identify abnormally low costs and unit rates by comparing them with the engineer's estimates, other substantially responsive bids, or recently awarded similar contracts;
 - (b) clarify and analyze the bidder's resource inputs and pricing, including overheads, contingencies and profit margins; and
 - (c) decide whether to accept or reject the bid.
- 37.3 With regard to ITB 37.2 (b) above, the Purchaser will seek a written explanation from the bidder of the reasons for the offered bid price, including a detailed analysis of costs and unit prices, by reference to the scope, proposed methodology, schedule, and allocation of risks and responsibilities. This may also include information regarding the economy of the manufacturing process; the services to be provided, or the construction method to be used; the technical solutions to be adopted; and any exceptionally favorable conditions available to the bidder for the goods or services proposed.
- 37.4 After examining the explanation given and the detailed price analyses presented by the bidder, the Purchaser may:
- (a) accept the bid, if the evidence provided satisfactorily accounts for the low bid price and costs, in which case the bid is not considered abnormally low;
 - (b) accept the bid, but require that the amount of the performance security be increased at the expense of the bidder to a level sufficient to protect

the Purchaser against financial loss. The amount of the performance security shall generally be not more than 20% of the contract price; or

- (c) reject the bid if the evidence provided does not satisfactorily account for the low bid price, and make a similar determination for the next lowest evaluated bid, if required

- 38. Post-qualification of the Bidder**
- 38.1 The Purchaser shall determine to its satisfaction whether the Bidder that is selected as having submitted the lowest evaluated and substantially responsive Bid is qualified to perform the Contract satisfactorily.
- 38.2 The determination shall be based upon an examination of the documentary evidence of the Bidder's qualifications submitted by the Bidder, pursuant to ITB 19. Unless permitted in the BDS, the determination shall not take into consideration the qualifications of other firms such as the Bidder's subsidiaries, parent entities, or affiliates.
- 38.3 An affirmative determination shall be a prerequisite for award of the Contract to the Bidder. The Purchaser reserves the right to reject the bid of any bidder found to be in circumstances described in GCC 35.2. A negative determination shall result in disqualification of the Bid, in which event the Purchaser shall proceed to the next lowest evaluated Bid to make a similar determination of that Bidder's capabilities to perform satisfactorily.
- 39. Purchaser's Right to Accept Any Bid, and to Reject Any or All Bids**
- 39.1 The Purchaser reserves the right to accept or reject any Bid, and to annul the bidding process and reject all Bids at any time prior to Contract award, without thereby incurring any liability to the Bidders. In case of annulment, all Bids submitted and specifically, bid securities, shall be promptly returned to the Bidders.
- 40. Notice of Intention for Award of Contract**
- 40.1 If Standstill provisions apply as specified in the BDS, the standstill period shall be defined in the BDS to specify the duration subsequent to notification of intention for award of contract (before making the actual contract award) within which any unsuccessful bidder can challenge the proposed award.

F. Award of Contract

- 41. Award Criteria**
- 41.1 The Purchaser shall award the Contract to the Bidder whose offer has been determined, in line with ITB 36 to ITB 38 above, to be the lowest evaluated Bid and is substantially responsive to the Bidding Document, provided further that the Bidder is determined to be qualified to perform the Contract satisfactorily.
- 42. Purchaser's Right to Vary Quantities at Time of Award**
- 42.1 At the time the Contract is awarded, the Purchaser reserves the right to increase or decrease the quantity of Goods and Related Services originally specified in Section 6 (Schedule of Supply), provided this does not exceed the percentages indicated in the BDS, and without any change in the unit prices or other terms and conditions of the Bid and the Bidding Document.

- 43. Notification of Award**
- 43.1 Prior to the expiration of the period of bid validity and upon expiry of the standstill period specified in ITB 40.1, or upon satisfactory resolution of a complaint filed within standstill period, if applicable, the Purchaser shall transmit the Notification of Award using the form included in Section 9 (Contract Forms) to the successful Bidder, in writing, that its Bid has been accepted. At the same time, the Purchaser also notify all other Bidders of the results of the bidding.
- 43.2 Unless standstill period applies, upon notification of award, unsuccessful Bidders may request in writing to the Purchaser for a debriefing seeking explanations on the grounds on which their Bids were not selected. The Purchaser shall promptly respond in writing and/or in a debriefing meeting to any unsuccessful Bidder who, after publication of contract award, requests a debriefing.
- 43.3 Until a formal Contract is prepared and executed, the notification of award shall constitute a binding Contract.
- 43.4 Within 2 weeks of the award of contract or expiry of the standstill period, where such period applies, or, if a complaint has been filed within the standstill period, upon receipt of ADB's confirmation of satisfactory resolution of the complaint, the Borrower shall publish in an English language newspaper or well-known freely accessible website the results identifying the Bid and lot or package numbers as applicable and the following information:
- (a) name of each Bidder who submitted a Bid;
 - (b) bid prices as read out at bid opening;
 - (c) name and evaluated prices of each Bid that was evaluated;
 - (d) name of Bidders whose Bids were rejected and the reasons for their rejection; and
 - (e) name of the winning Bidder, and the price it offered, as well as the duration and summary scope of the contract awarded.
- 44. Signing of Contract**
- 44.1 Promptly after notification, the Purchaser shall send to the successful Bidder the Contract Agreement.
- 44.2 Within 28 days of receipt of the Contract Agreement, the successful Bidder shall sign, date, and return it to the Purchaser.
- 45. Performance Security**
- 45.1 Within 28 days of the receipt of notification of award from the Purchaser, the successful Bidder shall furnish the Performance Security in accordance with the GCC, subject to ITB 37, using for that purpose the Performance Security Form included in Section 9 (Contract Forms), or another form acceptable to the Purchaser. If the bank issuing performance security is located outside the Purchaser's country, it shall be counter-guaranteed or encashable by a bank in the Purchaser's country.
- 45.2 Failure of the successful Bidder to submit the abovementioned performance security or sign the Contract Agreement shall constitute sufficient grounds for the annulment of the award and forfeiture of the bid security or execution of the Bid-Securing Declaration. In that event,

the Purchaser may award the Contract to the next lowest evaluated Bidder whose offer is substantially responsive and is determined by the Purchaser to be qualified to perform the Contract satisfactorily.

**46. Bidding-
Related
Complaints**

- 46.1 The procedures for dealing with Bidding-Related Complaints arising out of this bidding process are specified in the BDS.

Section 2: Bid Data Sheet

A. General	
ITB 1.1	The number of the Invitation for Bids (IFB) is: (1564) DWPSD/STEPUP/G-13/2022-2023/
ITB 1.1	The Purchaser is: Project Management Unit, Skills Training and Education Pathways Upgradation Project (STEPUP), Department of Workforce Planning and Skills Development, Ministry of Education and Skills Development (MoESD).
ITB 1.1	<p>The name of the open competitive bidding (OCB) is: Procurement of Automobile Tools and Equipment (Lot1-8).</p> <p>The identification number of the OCB is: (1564) DWPSD/STEPUP/G-13/2022-2023/</p> <p>The number and identification of lots comprising this OCB is:</p> <p>Procurement of Automobile Equipment</p> <ol style="list-style-type: none"> 1. Lot 1- Automobile (Hybrid) 2. Lot 2- Automobile Transmission Vehicle 3. Lot 3- Measuring Equipment 4. Lot 4- Automobile Repair Tools 5. Lot 5- Automobile Equipment 6. Lot 6-Automobile Simulator 7. Lot-7 Automobile Parts 8. Lot -8 Furniture
ITB 2.1	The Borrower is: Ministry of Education and Skills Development (MoESD)
ITB 2.1	The name of the Project is: Skills Training and Education Pathways Upgradation Project (STEPUP).
B. Contents of Bidding Document	
ITB 7.1	<p>For clarification purposes only, the Purchaser's address is:</p> <p>Attention: Project Director, STEPUP, DWPSD, MoESD.</p> <p>Street address: Thimphu: Bhutan</p> <p>Telephone: 02335923</p> <p>E-mail: gyeltshenpmu17@gmail.com</p>
C. Preparation of Bids	
ITB 10.1	The language of the Bid is: English

Bidding Document for G-13 Procurement of Automobile Tools and Equipment (Lot 1-8)

ITB 11.1	<p>The Bidder shall submit with its Bid the following documents:</p> <ul style="list-style-type: none"> (a) Bid Submission Sheet and the applicable Price Schedules, in accordance with ITB 12, ITB 14, and ITB 15; (b) Bid-Securing Declaration, in accordance with ITB 21; (c) written confirmation authorizing the signatory of the Bid to commit the Bidder, in accordance with ITB 22; (d) documentary evidence in accordance with ITB 16, establishing the Bidder's eligibility to bid; (e) documentary evidence in accordance with ITB 17, that the Goods and Related Services to be supplied by the Bidder are of eligible origin; (f) documentary evidence in accordance with ITB 18 and ITB 31, that the Goods and Related Services conform to the Bidding Document; (g) documentary evidence in accordance with ITB 19, establishing the Bidder's qualifications to perform the contract if its Bid is accepted.
ITB 12.2	<p>The units and prices in figures entered into the Price Schedules should be typewritten or if written by hand, must be in print form. Price Schedules not presented accordingly may be considered nonresponsive.</p>
ITB 13.1	<p>Alternative Bids shall not be permitted.</p>
ITB 14.5	<p>The Incoterms edition is: 2020</p>
ITB 14.6 (b) (i)	<p>For Goods offered from outside the Purchaser's country, the Bidder shall quote prices using the following Incoterms: Incoterm 2020, DPU (Delivered at Place Unloaded) and insurance shall be the responsibility of the supplier.</p> <p>For Goods offered from within the Purchaser's country, the bidder shall quote prices using the following Incoterms: Incoterm 2020, EXW (ex-works, ex-factory, ex warehouse, ex showroom, or off-the-shelf, as applicable).</p>
ITB 14.7	<p>The prices quoted by the Bidder shall not be adjustable.</p>
ITB 14.8	<p>Prices quoted for each lot shall correspond at least to 100 % of the items specified for each lot.</p> <p>Prices quoted for each item of a lot shall correspond at least to 100% of items shown the quantities specified for this item of a lot.</p>
ITB 19.2	<p>The Bidder shall include with its bid the Manufacturer's Authorization for the following item(s): All items as mentioned in section 6-Schedule of Supply (list of goods and related services) and as in price schedule.</p> <p>The Bidder is required to submit documentation to substantiate that it is an authorized dealer, distributor or reseller of the goods being procured.</p> <p><i>Non submission of Manufacturers Authorization or dealership shall be the basis for rejection of the bid.</i></p>

ITB 19.3	The Bidder is required to include with its bid, evidence that it will be represented by an Agent in the Purchaser's country.
ITB 20.1	The bid validity period shall be 120 days from the date of bid opening.
ITB 21.1	The Bidder shall furnish a Bid-Securing Declaration.
ITB 21.2	The Purchaser will declare a Bidder ineligible to be awarded a Contract for a period of two (2) years , if the bidder fails to comply with the terms and conditions of the tender document.
ITB 21.4	Any bid not accompanied by a substantially compliant Bid-Securing Declaration shall be rejected as nonresponsive.
ITB 22.1	In addition to the original Bid, the number of copies is: one
ITB 22.2	The written confirmation of Authorization to sign on behalf of the Bidder shall consist of: "An organizational document, board resolution or its equivalent, or power of attorney specifying the representative's authority to sign the Bid on behalf of, and to legally bind, the Bidder. If the Bidder is an intended or an existing joint venture, the power of attorney should be signed by all partners and specify the authority of the named representative of the joint venture to sign on behalf of, and legally bind, the intended or existing joint venture. If the joint venture has not yet been formed, also include evidence from all proposed joint venture partners of their intent to enter into a joint venture in the event of a contract award in accordance with ITB 16.1 (b)"
ITB 22.2	The Bidder shall submit an acceptable authorization as a part of the bid document.
D. Submission and Opening of Bids	
ITB 23.1	Bidders shall submit their Bids by mail or by hand.
ITB 23.1 (b)	Electronic bidding submission procedures shall be: NA
ITB 23.2 (c)	The additional identification marks are: NA
ITB 24.1	For bid submission purposes only, the Purchaser's address is: Attention: Project Director, Project Management Unit, Skills Training and Education Pathways Upgradation Project, Department of Workforce Planning and Skills Development, Ministry of Education and Skills Development (MoESD) Thimphu, Bhutan
ITB 24.1	The deadline for bid submission is:

	Date: 31/05/2023 Time: 2.30PM
ITB 27.1	The bid opening shall take place at: Street address: Project Management Unit, STEPUP, DWPSD, MoESD Floor/Room number: Conference Hall Date: 31/05/2023 Time: 3.00PM
ITB 27.1	The electronic bid opening procedure shall be as follows: NA
ITB 27.3	The Bid Submission Sheet and Price Schedules shall be initialed by three (3) representatives of the Purchaser attending Bid opening.
E. Evaluation and Comparison of Bids	
ITB 34.1	The currency that shall be used for bid evaluation and comparison purposes to convert all bid prices expressed in various currencies into a single currency is: Ngultrum
ITB 35.1	Domestic preference shall not apply.
ITB 38.2	The qualifications of other firms such as the Bidder's subsidiaries, parent entities, or affiliates shall not be permitted.
ITB 40.1	Standstill provisions shall apply. The duration of standstill period will be 10 days from the date of notice of intention for award of contract. The Purchaser shall, at the start of the standstill period, notify in writing each Bidder that submitted a bid, of its intention to award a contract to the successful bidder at the end of standstill period. The notification using the form included in Section 9 (Contract Forms) shall include the following information: (a) the name of each Bidder who submitted a Bid; (b) the bid prices as read out at bid opening; (c) the name and evaluated prices of each Bid that was evaluated; (d) the name of Bidders whose bids were rejected and the reasons for their rejection; (e) the name of the winning Bidder, and the price it offered, as well as the duration and summary scope of the contract awarded; and (f) a statement of the reason(s) the bid of the unsuccessful Bidder to whom the notification is addressed was unsuccessful, unless the price information under (e) of this paragraph already reveals the reason.
F. Award of Contract	

ITB 42.1	The maximum percentage by which quantities may be increased is: 15% The maximum percentage by which quantities may be decreased is: 15%
ITB 46.1	The Bidder should submit its complaint following these procedures, in writing, to: For the attention: Mr. Norbu Wangchuk Title/position: Project Director Purchaser: Ministry of Education and Skills Development (MoESD) E-mail address: gyeltshenpmu17@gmail.com

Section 3: Evaluation and Qualification Criteria

Table of Criteria

1.	Evaluation Criteria	Error! Bookmark not defined.-3
1.1	Technical Criteria	3-3
1.2	Domestic Preference	3-3
1.3	Economic Criteria	
	1.3.1 Adjustment for Scope.....	3-3
	1.3.1.1 Local Handling and Inland Transportation.....	3-3
	1.3.1.2 Minor Omissions or Missing Items.....	3-3
	1.3.2 Adjustment for Deviations from the Terms of Payment	3-3
	1.3.3 Adjustment for Deviations in the Delivery and Completion Schedule.....	3-4
	1.3.4 Operating and Maintenance Costs	3-4
	1.3.5 Spare Parts	3-4
	1.3.6 Performance and Productivity of the Goods	3-4
1.4	Multiple Lots (Contracts)	3-4
2.	Qualification Criteria	Error! Bookmark not defined.-5
	Contract Type A. Off-the-Shelf Items	3-5
2.1	Eligibility	3-5
	2.1.1 Nationality	3-5
	2.1.2 Conflict of Interest.....	3-5
	2.1.3 ADB Eligibility	3-5
	2.1.4 Government-Owned Enterprise	3-5
	2.1.5 United Nations Eligibility	3-5
2.2	Experience and Technical Capacity	3-6
	2.2.1 Contractual Experience.....	3-6
2.3	Financial Situation	3-7
	2.3.1 Historical Financial Performance	3-7
	2.3.2 Size of Operation (Average Annual Turnover) (Optional).....	3-7
	Contract Type B. Custom-Designed, High-Value, and Technically Complex Items	3-8
2.1	Eligibility	3-8

2.1.1 Nationality	3-8
2.1.2 Conflict of Interest	3-8
2.1.3 ADB Eligibility.....	3-8
2.1.4 Government-Owned Enterprise	3-8
2.1.5 United Nations Eligibility	3-8
2.2 Historical Contract Nonperformance.....	3-9
2.2.1 History of Nonperforming Contracts.....	3-9
2.2.2 Suspension Based on Execution of Bid-Securing Declaration	3-9
2.2.3 Pending Litigation	3-10
2.3 Experience and Technical Capacity	3-11
2.3.1 Contractual Experience.....	3-11
2.3.2 Technical Experience.....	3-11
2.3.3 Production Capacity.....	3-12
2.4 Financial Situation	3-13
2.4.1 Historical Financial Performance	3-13
2.4.2 Size of Operation (Average Annual Turnover).....	3-13
2.4.3 Cash Flow Capacity	3-14

1. Evaluation Criteria

1.1 Technical Criteria

The cost of all quantifiable deviations or deficiencies from the technical requirements as specified in Section 6 (Schedule of Supply) shall be evaluated. The Purchaser will make its own assessment of the cost of these deviations or deficiencies for the purpose of ensuring fair comparison of Bids.

1.2 Domestic Preference shall not apply

If domestic preference is provided for under ITB 35.1, the following procedure shall apply:

1.3 Economic Criteria

1.3.1 Adjustment for Scope

1.3.1.1 Local Handling and Inland Transportation

Costs for inland transportation, insurance, and other incidental costs for delivery of the goods from the EXW premises, or port of entry, or border point to Project Site as defined in Section 6 (Schedule of Supply), shall be quoted in the Price Schedule for Related Services to Be Offered from Outside and Within the Purchaser's Country provided In Section 4 (Bidding Forms). These costs will be taken into account during bid evaluation. If a Bidder fails to include such costs in its Bid, then these costs will be estimated by the Purchaser on the basis of published tariffs by the rail or road transport agencies, insurance companies, or other appropriate sources, and added to EXW or CIF or CIP price.

1.3.1.2 Minor Omissions or Missing Items

Pursuant to ITB 32.3, the cost of all quantifiable nonmaterial nonconformities or omissions from the contractual and commercial conditions shall be evaluated. The Purchaser will make its own assessment of the cost of any nonmaterial nonconformities and omissions for the purpose of ensuring fair comparison of Bids.

1.3.2 Adjustment for Deviations from the Terms of Payment

"Deviations from the Terms of Payment as specified in SCC 16.1 are not permitted."

1.3.3 Adjustment for Deviations in the Delivery and Completion Schedule

"Deviations from the Delivery and Completion Schedule specified in Section 6 (Schedule of Supply) are not permitted."

1.3.4 Operation and Maintenance (O&M) Costs

Not Applicable

1.3.5 Spare Parts

Not applicable, but the bidder is required to include with its bid, evidence that it will be represented by an agent in purchaser's country.

1.3.6 Performance and Productivity of the Goods

The method of calculation shall be the following: Not Applicable

1.4 Multiple Lots (Contracts)

Goods are grouped in lots. The Purchaser will evaluate and compare Bids on the basis of a lot, or a combination of lots, or as a total of lots to arrive at the least cost combination for the Purchaser by taking into account discounts offered by Bidders in case of award of multiple contracts.

If a Bidder as defined in ITB 4.1 submits successful Bids for multiple lots (lowest evaluated substantially responsive Bids), the evaluation will also include an assessment of the Bidder's capacity to meet the aggregated qualifying requirements relating to **financial capacity and size of operation**.

Further, the bidder should have successfully supplied as main supplier within the last three (3) years the items similar to the scope of supply described in Section 6 (Schedule of Supply) worth of value as indicated:

Lots	Estimated Amount
Lot 1	Nu. 2.800
Lot 2	Nu. 1.332
Lot 3	Nu. 4.752
Lot 4	Nu. 1.449
Lot 5	Nu. 4.378
Lot 6	Nu. 3.207
Lot 7	Nu. 0.512
Lot 8	Nu. 0.706

2. Qualification Criteria

Contract Type A: Off-the-Shelf Items

2.1 Eligibility

Criteria	Compliance Requirements			Documents	
Requirement	Single Entity	Joint Venture			Submission Requirements
		All Partners Combined	Each Partner	One Partner	

2.1.1 Nationality

Nationality in accordance with ITB 4.2.	Must meet requirement	Must meet requirement	Must meet requirement	Not applicable	Bid Submission Sheet; Forms ELI – 1 and ELI – 2
---	-----------------------	-----------------------	-----------------------	----------------	---

2.1.2 Conflict of Interest

No conflicts of interest in accordance with ITB 4.3.	Must meet requirement	Must meet requirement	Must meet requirement	Not applicable	Bid Submission Sheet
--	-----------------------	-----------------------	-----------------------	----------------	----------------------

2.1.3 ADB Eligibility

Not having been declared ineligible by ADB, as described in ITB 4.4.	Must meet requirement	Must meet requirement	Must meet requirement	Not applicable	Bid Submission Sheet
--	-----------------------	-----------------------	-----------------------	----------------	----------------------

2.1.4 Government-Owned Enterprise

Bidder required to meet conditions of ITB 4.5.	Must meet requirement	Must meet requirement	Must meet requirement	Not applicable	Bid Submission Sheet; Forms ELI – 1 and ELI – 2
--	-----------------------	-----------------------	-----------------------	----------------	---

2.1.5 United Nations Eligibility

Not having been excluded by an act of compliance with a United Nations Security Council resolution in accordance with ITB 4.8.	Must meet requirement	Must meet requirement	Must meet requirement	Not applicable	Bid Submission Sheet
--	-----------------------	-----------------------	-----------------------	----------------	----------------------

2.2 Experience and Technical Capacity

2.2.1 Contractual Experience

Criteria		Compliance Requirements			Documents	
Requirement	Single Entity	Joint Venture			Submission Requirements	
		All Partners Combined	Each Partner	One Partner		
Successful completion as main supplier within the last three (3) years, a project with nature, and complexity similar to the scope of supply described below and as mentioned in section 6 (Schedule of Supply).		Must meet requirement	Must meet requirement	Not applicable	Not applicable	Form EXP – 1 ^a
Lot	Amount					
Lot 1	Nu. 2.800					
Lot 2	Nu. 1.332					
Lot 3	Nu. 4.752					
Lot 4	Nu. 1.449					
Lot 5	Nu. 4.378					
Lot 6	Nu. 3.207					
Lot 7	Nu. 0.512					
Lot 8	Nu. 0.706					

^a In addition to the submission of Form EXP-1, the Bidder shall provide the Signed Contract Agreement.

2.3 Financial Situation

2.3.1 Historical Financial Performance

Criteria	Compliance Requirements				Documents
Requirement	Single Entity	Joint Venture			Submission Requirements
		All Partners Combined	Each Partner	One Partner	
Submission of audited financial statements or, if not required by the law of the Bidder's country, other financial statements acceptable to the Purchaser, for the last three (3) years to demonstrate the current soundness of the Bidder's financial position. As a minimum, the Bidder's net worth for the last year calculated as the difference between total assets and total liabilities should be positive.	Must meet requirement	Not applicable	Must meet requirement	Not applicable	Form FIN – 1

Section 4: Bidding Forms

Table of Forms

Bid Submission Sheet	4-45
Price Schedule for Goods to Be Offered from Within the Purchaser's Country 4-Error! Bookmark not defined.	
Price Schedule for Goods to Be Offered from Outside the Purchaser's Country.....	4-50
Price Schedule for Related Services to Be Offered from Outside and Within the Purchaser's Country	4-50
Bid Security.....	4-9
Bid-Securing Declaration	4-10
Manufacturer's Authorization	4-11
Affiliate Company Guarantee	4-12
Bidder's Qualification.....	4-13
Form ELI – 1: Bidder's Information Sheet	4-14
Form ELI - 2: Joint Venture Information Sheet.....	4-15
Form CON - 1: Historical Contract Nonperformance	4-16
Form EXP - 1: Contractual Experience	4-17
Form EXP - 2: Technical Experience	4-18
Form EXP - 3: Production Capacity	4-19
Form FIN - 1: Historical Financial Performance	4-20
Form FIN - 2: Size of Operation (Average Annual Turnover).....	4-21
Form FIN - 3: Cash Flow Capacity	4-22

Bid Submission Sheet

- Note -

The Bidder must accomplish the Bid Submission Sheet on its letterhead clearly showing the Bidder's complete name and address.

Date: _____

Open Competitive Bidding (OCB) No.: _____

Invitation for Bid (IFB) No.: _____

Alternative No.: _____

To: *[insert complete name of the Purchaser]*

We, the undersigned, declare that:

- (a) We have examined and have no reservations to the Bidding Documents, including Addenda issued in accordance with Instructions to Bidders (ITB) 8.
- (b) We acknowledge that we have read and understand ADB's Anticorruption Policy (1998) and Integrity Principles and Guidelines (2015), both as amended from time to time.
- (c) We offer to supply in conformity with the Bidding Documents and in accordance with the delivery schedule specified in Section 6 (Schedule of Supply), the following Goods and Related Services: *[insert a brief description of the goods and related services]*
- (d) The total price of our Bid, excluding any discounts offered in item (d) below, is

[amount of foreign currency in words], [amount in figures], and [amount of local currency in words], [amount in figures]

The total bid price from the price schedules should be entered by the bidder inside this box. Absence of the

- (e) The discounts offered and the methodology for their application are as follows:

Discounts: If our Bid is accepted, the following discounts shall apply: *[specify in detail each discount offered and the specific item of the Schedule of Supply to which it applies]*

Methodology of Application of the Discounts: The discounts shall be applied using the following method:
[specify in detail the method that shall be used to apply the discounts]

- (f) Our Bid shall be valid for a period of *[insert validity period as specified in ITB 20.1 of the BDS.]* days starts from the date fixed for the bid submission deadline in accordance with ITB 24.1, and it shall remain binding upon us and may be accepted at any time before the expiration of that period.
- (g) If our Bid is accepted, we commit to obtain a Performance Security in accordance with the Bidding Documents.
- (h) Our firm, including any subcontractors or suppliers for any part of the Contract, have nationalities from eligible countries in accordance with ITB 4.2.
- (i) We, our directors, key officers, key personnel, including any subcontractors, consultants, subconsultants, manufacturers, service providers or suppliers for any part of the contract, do not have any conflict of interest in accordance with ITB 4.3.

If there is any conflict of interest, please state details:

- (i) Parties involved in the conflict of interest: _____
- (ii) Details about the conflict of interest: _____
- (j) We are not participating, as a Bidder, either individually or as partner in a Joint Venture, in more than one Bid in this bidding process in accordance with ITB 4.3(e), other than alternative offers in accordance with the Bidding Documents.
- (k) Our firm, Joint Venture partners, our respective direct and indirect shareholders, directors, key officers, key personnel, associates, parent company, affiliates or subsidiaries, including any Subcontractors, consultants, subconsultants, manufacturers, service providers or Suppliers for any part of the contract, are not subject to, or not controlled by any entity or individual that is subject to a temporary suspension or a debarment imposed by the Asian Development Bank; or a debarment imposed by the Asian Development Bank in accordance with the Agreement for Mutual Enforcement of Debarment Decisions between the Asian Development Bank and other development banks.¹
- (l) Our firm, Joint Venture partners, our respective direct and indirect shareholders, directors, key officers, key personnel, associates, parent company, affiliates or subsidiaries, including any Subcontractors, consultants, subconsultants, manufacturers, service providers or Suppliers for any part of the contract, are not under ongoing investigation and/or sanctions proceedings by the Asian Development Bank or any multilateral development bank.

¹These institutions include African Development Bank, European Bank for Reconstruction and Development (EBRD), Inter-American Development Bank (IADB), and the World Bank Group. According to paragraph 9 of the Agreement, other international financial institutions may join upon the consent of all Participating Institutions and signature of a Letter of Adherence by the international financial institution substantially in the form provided (Annex B to the Agreement). Upon adherence, such international financial institution shall become a Participating Institution for purposes of the Agreement. Bidders are advised to check www.adb.org/integrity for updates.

If under ongoing investigation and/or sanction proceedings by the Asian Development Bank or any multilateral development bank, please state details:

- (i) Name of the multilateral development bank: _____
- (ii) Reason for the ongoing investigation/allegations: _____

- (m) Our firm, Joint Venture partners, our respective direct and indirect shareholders, directors, key officers, key personnel, associates, parent company, affiliates or subsidiaries, including any Subcontractors, consultants, subconsultants, manufacturers, service providers or Suppliers for any part of the Contract, are not temporarily suspended, debarred, declared ineligible, or subject to any national and/or international sanctions by any country, any international organization, any multilateral development bank and other donor agency.

If so temporarily suspended, debarred, declared ineligible, or subject to any national and/or international sanctions by any country, any international organization, any multilateral development bank and other donor agency, please state details (as applicable to each Joint Venture partner, their respective direct or indirect shareholders, directors, key officers, key personnel, associate, parent company, affiliate, subsidiaries, Subcontractors, consultants, subconsultants, manufacturers, service providers and/or Suppliers):

- (i) Name of Institution: _____
- (ii) Period of the temporary suspension, debarment, ineligibility, or national or international sanction [*start and end date*]: _____
- (iii) Reason for the temporary suspension, debarment, ineligibility, or national or international sanction:

- (n) Our firm, Joint Venture partners, associates, parent company, affiliates or subsidiaries', including any Subcontractors, consultants, subconsultants, manufacturers, service providers, Suppliers, key officers, directors and key personnel have never been charged or convicted with any criminal offense (including felonies but excluding misdemeanors) or infractions and/or violations of ordinance; nor charged or found liable in any civil or administrative proceedings in the last 10 years; or undergoing investigation for such, or subject to any criminal, civil or administrative orders, monitorship or enforcement actions.

If so charged, convicted/found liable, under ongoing investigation, or subject to orders, monitorship or enforcement actions, please state details:

- (i) Nature of the offense, violation, proceedings, investigation, and/or monitorship or enforcement actions:

- (ii) Court, area of jurisdiction and/or the enforcement agency: _____
- (iii) Resolution [*i.e. dismissed; settled; or convicted/duration of penalty*]: _____
- (iv) Other relevant details [*please specify*]: _____

- (o) Our firm, Joint Venture partners, our respective direct and indirect shareholders, directors, key officers, key personnel, associates, affiliates or subsidiaries, including any Subcontractors, consultants,

Bidding Document for G-13 Procurement of Automobile Tools and Equipment (Lot 1-8)

subconsultants, manufacturers, service providers or Suppliers, can make and receive electronic fund transfer payments through the international banking system or otherwise discharge the Purchaser's obligation upon initiation of wire transfer.

If unable to make or receive funds through the international banking system or otherwise discharge the Purchaser's obligation upon initiation of wire transfer, please state the details:

- (i) Nature of the restriction: _____
- (ii) Jurisdiction of the restriction: _____
- (iii) Other relevant details: _____

- (p) Our firm, Joint Venture partners, associates, parent company, affiliates or subsidiaries, including any Subcontractors, consultants, subconsultants, manufacturers, service providers or Suppliers, key officers, directors and key personnel are not from a country which is prohibited to export goods or services to, or receive any payments from the Purchaser's country and/or are not prohibited to receive payments for particular goods or services by the Purchaser's country by an act of compliance with a decision of the United Nations Security Council taken under Chapter VII of the Charter of the United Nations.
- (q) We understand that it is our obligation to notify the Purchaser of any changes in connection with the matters described in paragraphs (i), (k), (l), (m), (n), (o), (p) and (t) of this Bid Submission Sheet.
- (r) [We are not a government-owned enterprise] / [We are a government-owned enterprise but meet the requirements of ITB 4.5].²
- (s) We have not been suspended nor declared ineligible by the Purchaser based on execution of a Bid-Securing Declaration in accordance with ITB 4.6.
- (t) We have paid, or intend to pay, either directly or indirectly, the following commissions, gratuities, or fees with respect to the bidding process or execution of the Contract:³

Name of Recipient	Address	Reason	Amount
_____	_____	_____	_____
_____	_____	_____	_____

- (u) We understand that this Bid, together with your written acceptance thereof included in your notification of award, shall constitute a binding contract between us, until a formal Contract is prepared and executed.
- (v) We understand that you are not bound to accept the lowest evaluated Bid or any other Bid that you may receive.

² Use one of the two options as appropriate.

³ If none has been paid or is to be paid, indicate "None."

- (w) At any time following submission of our Bid, We shall permit, and shall cause our Joint Venture partners, directors, key officers, key personnel, associates, parent company, affiliates or subsidiaries, including any Subcontractors, consultants, subconsultants, manufacturers, service providers or Suppliers for any part of the contract to permit ADB or its representative to inspect our site, assets, accounts and records and other documents relating to the bid submission and to have them audited by auditors appointed by ADB. We understand that failure of this obligation may constitute obstructive practice that may result in debarment and/or contract termination.

- (x) Regardless of whether the contract will be awarded to us, we shall preserve all accounts, records and other documents related to bid submission for at least 3 years from the date of submission of the bid or the period prescribed in applicable law, whichever is longer.

- (y) If we are awarded the contract, we shall preserve all accounts, records and other documents related to the procurement and execution of the contract for at least 5 years after completing the works contemplated in the relevant contracts or the period prescribed in applicable law, whichever is longer.

- (z) We certify on behalf of the Bidder, that the information provided in the bid has been fully reviewed, given in good faith, and to the best of our knowledge is true and complete. We understand that it is our obligation to inform the Purchaser of any changes to the information as and when it becomes known to us. We understand that any misrepresentation that knowingly or recklessly misleads, or attempts to mislead may lead to the automatic rejection of the Bid or cancellation of the contract, if awarded, and may result in remedial actions, in accordance with ADB's Anticorruption Policy (1998, as amended to date) and Integrity Principles and Guidelines (2017, as amended from time to time).

Name _____

In the capacity of _____

Signed _____

Duly authorized to sign the Bid for and on behalf of _____

Date _____

Price Schedule for Related Services to Be Offered from Outside and Within the Purchaser's Country

Name of Bidder _____ IFB Number _____ Page ___ of ___

Lot 1-Automobile (Hybrid)

Item No.	Description	Country of Origin	Unit of Measurement	Quantity	Unit Price		Total Price per Item	
					(a)	(b)	(a)	(b)
					Foreign Currency	Local Currency	Foreign Currency	Local Currency
1	2	3		4	5(a)	5(b)	6(a) = 4 x 5(a)	6(b) = 4 x 5(b)
1	Hybrid Vehicle		No.	1				
Total Amount								

Notes:

Columns 5 and 6: Currencies in accordance with ITB 15

Prices are to be quoted inclusive of all customs duties, sales and other similar taxes applicable in the Purchaser's country and payable on the Related Services, if the Contract is awarded to the Bidder

Name _____

In the capacity of _____

Signed _____

Duly authorized to sign the Bid for and on behalf of _____

Price Schedule for Related Services

to Be Offered from Outside and Within the Purchaser's Country

Name of Bidder _____ IFB Number _____ Page ___ of ___

Lot 2-Automatic Transmission Vehicle

Item No.	Description	Country of Origin	Unit of Measurement	Quantity	Unit Price		Total Price per Item	
					(a)	(b)	(a)	(b)
					Foreign Currency	Local Currency	Foreign Currency	Local Currency
1	2	3		4	5(a)	5(b)	6(a) = 4 x 5(a)	6(b) = 4 x 5(b)
1	Auto Transmission Vehicle		Nos	1				
2	Continuously Variable Transmission		Nos	2				
Total Amount								

Notes:

Columns 5 and 6: Currencies in accordance with ITB 15

Prices are to be quoted inclusive of all customs duties, sales and other similar taxes applicable in the Purchaser's country and payable on the Related Services, if the Contract is awarded to the Bidder

The bidder shall award the contract to the supplier whose bid has been determined to be substantially responsive to this lot under this bid and who has offered the lowest price for this lot as a whole. However, in case one of the bidders are fully responsive for all the items under this lot, bid will be evaluated on item basis and contract will be awarded to the firms offering the lowest evaluated cost of the items.

Name _____

In the capacity of _____

Signed _____

Duly authorized to sign the Bid for and on behalf of _____

Date _____

Price Schedule for Related Services to Be Offered from Outside and Within the Purchaser's Country

Bidding Document for G-13 Procurement of Automobile Tools and Equipment (Lot 1-8)

Name of Bidder _____ IFB Number _____ Page ___ of ___

Lot 3 Measuring Equipment

Item No.	Description	Country of Origin	Unit of Measurement	Quantity	Unit Price		Total Price per Item	
					(a)	(b)	(a)	(b)
					Foreign Currency	Local Currency	Foreign Currency	Local Currency
					5(a)	5(b)	6(a) = 4 x 5(a)	6(b) = 4 x 5(b)
1	Ammeter		Nos	2				
2	Clampmeter		Nos	10				
3	Pen Style Voltage- Probe		Nos	20				
4	Specific gravity meter		Nos	4				
5	Engineer's Square		Nos	6				
6	Small Hole Gauge Set		Set	4				
7	Cooling System Analyser		Set	1				
8	Engine Compression Tester for petrol engine		Set	2				
9	Metric Torque Wrench with 40-200Nm range		Nos	4				
10	Outside Micrometer (50-75mm)		Nos	10				
11	Outside Micrometer (75-100mm)		Nos	10				
12	Vernier Caliper (300mm)		Nos	7				
13	Drive Belt Tension Gauge		Nos	4				

Bidding Document for G-13 Procurement of Automobile Tools and Equipment (Lot 1-8)

14	Fuel Pressure Gauge		Set	4				
15	Plasti gauge		Set	20				
16	Cylinder Bore Gauge		Set	10				
17	Straight Edge		Nos	6				
18	Telescopic Gauge set		Set	10				
19	Milli-ohm meter CAT-IV		Nos	2				
20	High voltage two-pole tester		Nos	2				
21	4-wheel Alignment Set & Hoist		Set	2				
22	Armature Growler		Nos	4				
23	Alternator / Starter Motor Test Bench		Nos	2				
24	High Rate Discharge Tester		Nos	2				
25	Automotive Oscilloscope		Nos	1				
26	Automotive Air-Conditioner Leakage Detector		Nos	1				
Total Amount								

Notes:

Columns 5 and 6: Currencies in accordance with ITB 15

Prices are to be quoted inclusive of all customs duties, sales and other similar taxes applicable in the Purchaser's country and payable on the Related Services, if the Contract is awarded to the Bidder

Name _____

In the capacity of _____

Signed _____

Duly authorized to sign the Bid for and on behalf of _____

Price Schedule for Related Services to Be Offered from Outside and Within the Purchaser's Country

Name of Bidder _____ IFB Number _____ Page ___ of ___

Lot 4-Automobile Repair Tools

Item No.	Description	Country of Origin	Unit of Measurement	Quantity	Unit Price		Total Price per Item	
					(a)	(b)	(a)	(b)
					Foreign Currency	Local Currency	Foreign Currency	Local Currency
	2	3		4	5(a)	5(b)	6(a) = 4 x 5(a)	6(b) = 4 x 5(b)
1	Suspension Arm Bushing Service Kit		Set	2				
2	MacPherson Strut Vise		Nos	2				
3	Disc and Drum Brake Service Set		Set	4				
4	Vacuum Operated Hydraulic Brake Bleeding Kit		Set	4				
5	Wire Stripper		Nos	12				
6	Bearing Pullers		Set	2				
7	Internal (Gear) Puller		Set	2				
8	Set, Assortment of Tools (Metric):		Set	10				
9	Oil Filter Removal Cup Wrench Set, in a Protective Box		Set	2				
10	7-Drawer Tool Trolley with Lock		Nos	10				

Bidding Document for G-13 Procurement of Automobile Tools and Equipment (Lot 1-8)

11	Valve Guide Driver/Removal Tool Set		Set	4				
12	Valve Guide Reamer Set		Set	4				
13	Vee-Blocks		Set	2				
14	Bearing Race & Seal Driver Set		Set	2				
15	Swivel joint spanner set		Set	6				
16	Portable Battery Power Screwdriver		Set	6				
17	Heat shrink blower		Nos	4				
18	Blind hole pulley kit		Set	4				
Total Amount								

Notes:
 Columns 5 and 6: Currencies in accordance with ITB 15
 Prices are to be quoted inclusive of all customs duties, sales and other similar taxes applicable in the Purchaser's country and payable on the Related Services, if the Contract is awarded to the Bidder

Name _____

In the capacity of _____

Signed _____

Duly authorized to sign the Bid for and on behalf of _____

Price Schedule for Related Services to Be Offered from Outside and Within the Purchaser's Country

Name of Bidder _____ IFB Number _____ Page ___ of ___

Lot 5: Automobile Equipment

Item No.	Description	Country of Origin	Unit of Measurement	Quantity	Unit Price		Total Price per Item	
					(a)	(b)	(a)	(b)
					Foreign Currency	Local Currency	Foreign Currency	Local Currency
1	2	3		4	5(a)	5(b)	6(a) = 4 x 5(a)	6(b) = 4 x 5(b)
1	Parts Washer		Nos	4				
2	Headlight Aimer		Nos	1				
3	5-Gas Vehicle Emissions Analyser		Nos	1				
4	Diesel Smoke Meter		Nos	1				
5	Recycling/Recharging Refrigerant Machine		Nos	1				
6	Electronic Ignition Analyser		Nos	2				
7	Hand Operated Vacuum Pump		Set	2				
8	Scissors Hoist		Nos	2				
9	2 Posts Electro-Hydraulic Hoist		Nos	1				
10	Compressed Air Hose Reels - ceiling hung		Nos	8				
11	Exhaust Extraction Hose Reels		Nos	4				
12	Hydraulic Jack - Lifting capacity up to 2000 kg		Nos	5				
13	Safety Stand		Set	6				

Bidding Document for G-13 Procurement of Automobile Tools and Equipment (Lot 1-8)

14	Waste Fluid / Oil Collection Tank		Set	2				
15	Forklift		Nos	1				
16	Pallet jack		Nos	1				
17	Portable Surface Table		Nos	2				
18	Air compressor		Nos	1				
19	Power Compression Crimping Tools		Nos	1				
20	Automatic Transmission Diagnostic Set		Set	1				
Total Amount								

Notes:
 Columns 5 and 6: Currencies in accordance with ITB 15
 Prices are to be quoted inclusive of all customs duties, sales and other similar taxes applicable in the Purchaser's country and payable on the Related Services, if the Contract is awarded to the Bidder

Name _____

In the capacity of _____

Signed _____

Duly authorized to sign the Bid for and on behalf of _____

Price Schedule for Related Services to Be Offered from Outside and Within the Purchaser's Country

Name of Bidder _____ IFB Number _____ Page ___ of ___

Lot 6: Automobile Simulator

Item No.	Description	Country of Origin	Unit of Measurement	Quantity	Unit Price		Total Price per Item	
					(a)	(b)	(a)	(b)
					Foreign Currency	Local Currency	Foreign Currency	Local Currency
					5(a)	5(b)	6(a) = 4 x 5(a)	6(b) = 4 x 5(b)
1	Air Bag Simulator		Nos	1				
2	Analog and Digital Trainer Kit		Set	1				
3	Electricity Master		Set	1				
4	Spark Ignition Engine Management System Model		Nos	1				
5	Common Rail Fuel System simulator		Nos	1				
6.	Four-stroke SI engine cut-away model		Nos	1				
7	Four-stroke Diesel engine cut-away model		Nos	1				
8	Two-stroke engine cut-away model		Nos	1				
9	Final drive and differential cut-away model		Nos	1				
Total Amount								

Bidding Document for G-13 Procurement of Automobile Tools and Equipment (Lot 1-8)

Notes:

Columns 5 and 6: Currencies in accordance with ITB 15

Prices are to be quoted inclusive of all customs duties, sales and other similar taxes applicable in the Purchaser's country and payable on the Related Services, if the Contract is awarded to the Bidder

Name _____

In the capacity of _____

Signed _____

Duly authorized to sign the Bid for and on behalf of

Price Schedule for Related Services to Be Offered from Outside and Within the Purchaser's Country

Name of Bidder _____ IFB Number _____ Page ___ of ___

Lot 7: Automobile Parts

Item No.	Description	Country of Origin	Unit of Measurement	Quantity	Unit Price		Total Price per Item	
					(a)	(b)	(a)	(b)
					Foreign Currency	Local Currency	Foreign Currency	Local Currency
1	2	3		4	5(a)	5(b)	6(a) = 4 x 5(a)	6(b) = 4 x 5(b)
1	Light Vehicle Automatic Transmission Assembly (Front Wheel Drive)		Nos	1				
2	Light Vehicle All-Wheel Drive Transmission		NOS	1				
3	Automatic Transmission (Rear Wheel Drive)		Nos	1				
4	Supercharger		Nos	1				
Total Amount								

Notes:

Columns 5 and 6: Currencies in accordance with ITB 15

Prices are to be quoted inclusive of all customs duties, sales and other similar taxes applicable in the Purchaser's country and payable on the Related Services, if the Contract is awarded to the Bidder

Name _____

In the capacity of _____

Signed _____

Duly authorized to sign the Bid for and on behalf of _____

Bidding Document for G-13 Procurement of Automobile Tools and Equipment (Lot 1-8)

Price Schedule for Related Services to Be Offered from Outside and Within the Purchaser's Country

Name of Bidder _____ IFB Number _____ Page ___ of ___

Lot 8 Furniture

Item No.	Description	Country of Origin	Unit of Measurement	Quantity	Unit Price		Total Price per Item	
					(a)	(b)	(a)	(b)
					Foreign Currency	Local Currency	Foreign Currency	Local Currency
1	2	3		4	5(a)	5(b)	6(a) = 4 x 5(a)	6(b) = 4 x 5(b)
1	Steel Cabinet, Full Height		Nos	6				
2	Students' Lab benches		Nos	18				
3	Storage Rack		Nos	10				
Total Amount								

Notes:

Columns 5 and 6: Currencies in accordance with ITB 15

Prices are to be quoted inclusive of all customs duties, sales and other similar taxes applicable in the Purchaser's country and payable on the Related Services, if the Contract is awarded to the Bidder

Name _____

In the capacity of _____

Signed _____

Duly authorized to sign the Bid for and on behalf of _____

Date ____

Bid-Securing Declaration

Date: *[insert date (as day, month, and year)]*Bid No.: *[insert number of bidding process]*Alternative No.: *[insert identification No if this is a bid for an alternative]*To: *[insert complete name of the Purchaser]*

We, the undersigned, declare that:

We understand that, according to your conditions, bids must be supported by a Bid-Securing Declaration.

We accept that we will automatically be suspended from being eligible for bidding in any contract with the Borrower for the period of time of *[insert number of years indicated in ITB 21.2 of the BDS]* starting on the date that we receive a notification from the Purchaser that our Bid-Securing Declaration is executed, if we are in breach of our obligation(s) under the bid conditions, because we

- (a) have withdrawn our Bid during the period of bid validity specified in the Bid Submission Sheet; or
- (b) do not accept the correction of errors in accordance with the Instructions to Bidders (hereinafter “the ITB”); or
- (b) having been notified of the acceptance of our Bid by the Purchaser during the period of bid validity, (i) fail or refuse to execute the Contract Agreement, if required, or (ii) fail or refuse to furnish the Performance Security, in accordance with the ITB.

We understand this Bid-Securing Declaration shall expire if we are not the successful Bidder, upon the earlier of (i) our receipt of your notification to us of the name of the successful Bidder; or (ii) 28 days after the expiration of our Bid.

Signed: *[insert signature of person whose name and capacity are shown]*In the capacity of *[insert legal capacity of person signing the Bid-Securing Declaration]*Name: *[insert complete name of person signing the Bid-Securing Declaration]*Duly authorized to sign the bid for and on behalf of *[insert complete name of the bidder]*Dated on _____ day of _____, _____ *[insert date of signing]*Corporate Seal *(where appropriate)*

Manufacturer's Authorization

Date: *[insert date (as day, month, and year) of bid submission]*

OCB No.: *[insert number of bidding process]*

To: *[insert complete name of the Purchaser]*

WHEREAS

We *[insert complete name of the manufacturer]*, who are official manufacturers of *[insert type of goods manufactured]*, having factories at *[insert full address of manufacturer's factories]*, do hereby authorize *[insert complete name of the bidder]* to submit a bid the purpose of which is to provide the following goods, manufactured by us *[insert name and/or brief description of the goods]*, and to subsequently negotiate and sign the Contract.

We hereby extend our full guarantee and warranty in accordance with Clause 28 of the General Conditions, with respect to the goods offered by the above firm.

Signed: *[insert signature(s) of authorized representative(s) of the manufacturer]*

Name: *[insert complete name(s) of authorized representative(s) of the manufacturer]*

Title: *[insert title]*

Duly authorized to sign this Authorization on behalf of *[insert complete name of the manufacturer]*

Dated on _____ day of _____, _____ *[insert date of signing]*

-- Note --

Bidding Document for G-13 Procurement of Automobile Tools and Equipment (Lot 1-8)

All italicized text is for use in preparing this form and shall be deleted from the final document.

The bidder shall require the manufacturer to fill out this form in accordance with the instructions indicated. This letter of authorization should be signed by a person with the proper authority to sign documents that are binding on the manufacturer. The bidder shall include it in its bid, if so indicated in the Bid Data Sheet (BDS).

AFFILIATE COMPANY GUARANTEE

Name of Contract/Contract No.: _____

Name and address of Purchaser: _____
[together with successors and assigns].

We have been informed that [name of Contractor] (hereinafter called the "Contractor") is submitting an offer for the above-referenced Contract in response to your invitation, and that the conditions of your invitation require its offer to be supported by an affiliate company guarantee.

In consideration of you, the Purchaser, awarding the Contract to the Contractor, we [name of affiliated company] irrevocably and unconditionally guarantee to you, as a primary obligation, that (i) throughout the duration of the Contract, we will make available to the Contractor our financial, technical capacity, expertise and resources required for the Contractor's satisfactory performance of the Contract; and (ii) we are fully committed, along with the Contractor, to ensuring a satisfactory performance of the Contract.

If the Contractor fails to so perform its obligations and liabilities and comply with the Contract, we will indemnify the Purchaser against and from all damages, losses and expenses (including legal fees and expenses) which arise from any such failure for which the Contractor is liable to the Purchaser under the Contract.

This guarantee shall come into full force and effect when the Contract comes into full force and effect. If the Contract does not come into full force and effect within a year of the date of this guarantee, or if you demonstrate that you do not intend to enter into the Contract with the Contractor, this guarantee shall be void and ineffective. This guarantee shall continue in full force and effect until all the Contractor's obligations and liabilities under the Contract have been discharged, when this guarantee shall expire and shall be returned to us, and our liability hereunder shall be discharged absolutely.

This guarantee shall apply and be supplemental to the Contract as amended or varied by the Purchaser and the Contractor from time to time. We hereby authorize them to agree on any such amendment or variation, the due performance of which and compliance with which by the Contractor are likewise guaranteed hereunder. Our obligations and liabilities under this guarantee shall not be discharged by any allowance of time or other indulgence whatsoever by the Purchaser to the Contractor, or by any variation or suspension of the works to be executed under the Contract, or by any amendments to the Contract or to the constitution of the Contractor or the Purchaser, or by any other matters, whether with or without our knowledge or consent.

This guarantee shall be governed by the law of the same country (or other jurisdiction) that governs the Contract and any dispute under this guarantee shall be finally settled under the [Rules or Arbitration provided in the Contract]. We confirm that the benefit of this guarantee may be assigned subject only to the provisions for assignment of the Contract.

Signed by:.....
(signature)
.....
(name)
.....
(position in parent/subsidiary company)

Signed by:
(signature)
.....
(name)
.....
(position in parent/subsidiary company)

Date:.....

-- Note --

If permitted in accordance with ITB 38.2 of the BDS, the Bidder shall provide the Affiliate Company Guarantee Form filled out and signed by each subsidiary, parent entity, or affiliate that the Bidder submits for consideration of the Purchaser in determining its qualifications.

Bidder's Qualification

To establish its qualifications to perform the contract in accordance with Section 3 (Evaluation and Qualification Criteria), the Bidder shall provide the following information requested in the corresponding Information Sheets.

Form ELI - 1: Bidder's Information Sheet

Bidder's Information			
		Information of the Bidder	If the Bidder is a subsidiary or branch, information of any parent company/companies
Names	Full legal name(s)		
	Full trading name(s) (if any)		
Addresses	Registered address(es)		
	Trading address(es)		
	Postal address(es) (if different from trading address)		
Type of organization			
Country of constitution/incorporation/registration			
Year of constitution/incorporation/registration			
Corporate or registration number			
In case of a Joint Venture, legal name of each partner			
Bidder's authorized representative <small>(name, address, telephone number(s), fax number(s) and e-mail address)</small>			

Attached are copies of the following documents:

1. In case of a single entity, articles of incorporation or constitution and company incorporation/registration of the legal entity named above, in accordance with ITB 4.1 and ITB 4.2
2. Authorization to represent the firm or Joint Venture named above, in accordance with ITB 22.2
3. In case of a Joint Venture, a letter of intent to form a Joint Venture or Joint Venture agreement, in accordance with ITB 4.1
4. In case of a government-owned enterprise, any additional documents not covered under 1 above required to comply with ITB 4.5

Form ELI - 2: Joint Venture Information Sheet

Each member of the Joint Venture must fill out this form separately.

Joint Venture Information	
Bidder's legal name	

		Information of Joint Venture Partner	If any Joint Venture Partner is a subsidiary or branch, information of any parent company/companies
Names	Full legal name		
	Full trading name(s) (if any)		
Addresses	Registered address(es)		
	Trading address(es)		
	Postal address(es) (if different from trading address)		
Type of organization			
Country of constitution/incorporation/registration			
Year of constitution/incorporation/registration			
Corporate or registration number			
Joint Venture Partner's authorized representative information (name, address, telephone number(s), fax number(s) and e-mail address)			
<p>Attached are copies of the following documents:</p> <ol style="list-style-type: none"> Articles of incorporation or constitution and company incorporation/registration of the legal entity named above, in accordance with ITB 4.1 and ITB 4.2 Authorization to represent the firm named above, in accordance with ITB 22.2 In the case of a government-owned enterprise, documents establishing legal and financial autonomy and compliance with commercial law, in accordance with ITB 4.5 			

Form CON – 1: Historical Contract Nonperformance

For Contract type B, each Bidder must fill out this form in accordance with Criteria 2.2.1 and 2.2.3 of Section 3 (Evaluation and Qualification Criteria) to describe any history of nonperforming contracts and pending litigation or arbitration formally commenced against it.

In case of a Joint Venture, each Joint Venture Partner must fill out this form separately and provide the Joint Venture Partner’s name:

Joint Venture Partner: _____

Table 1: History of Nonperforming Contracts			
<p>Choose one of the following:</p> <p><input type="checkbox"/> No nonperforming contracts.</p> <p><input type="checkbox"/> Below is a description of nonperforming contracts involving the Bidder (or each Joint Venture partner if Bidder is a Joint Venture).</p>			
Year	Description	Amount of Nonperformed Portion of Contract (\$ equivalent)	Total Contract Amount (\$ equivalent)
<i>[insert year]</i>	<p>Contract Identification: <i>[indicate complete contract name/ number, and any other identification]</i></p> <p>Name of Purchaser: <i>[insert full name]</i></p> <p>Address of Purchaser: <i>[insert street/city/country]</i></p> <p>Reason(s) for nonperformance: <i>[indicate main reason(s)]</i></p>	<i>[insert amount]</i>	<i>[insert amount]</i>
Table 2: Pending Litigation and Arbitration			
<p>Choose one of the following:</p> <p><input type="checkbox"/> No pending litigation, arbitration or any other material events impacting the net worth and/or liquidity of the bidder.</p> <p><input type="checkbox"/> Below is a description of all pending litigation, arbitration involving the Bidder or any other material events impacting the net worth and/or liquidity of the bidder (or each Joint Venture partner if Bidder is a Joint Venture).</p>			
Year	Matter in Dispute	Value of Pending Claim in \$ Equivalent	Value of Pending Claim as a Percentage of Net Worth

<p><i>[insert year]</i></p>	<p>Contract Identification, as applicable: <i>[indicate complete contract name/ number, and any other identification]</i></p> <p>Name of Purchaser, parties involved in the material events impacting the net worth and/or liquidity of the bidder: <i>[insert full name]</i></p> <p>Address of Purchaser, parties involved in the material events impacting the net worth and/or liquidity of the bidder: <i>[insert street/city/country]</i></p> <p>Matter of Dispute: <i>[indicate full description of dispute]</i> Party who initiated the dispute: <i>[indicate "Purchaser" or "Contractor"]</i> Status: <i>[indicate status of dispute]</i></p>	<p><i>[insert amount]</i></p>	<p><i>[insert amount]</i></p>
-----------------------------	---	-------------------------------	-------------------------------

- Note -

Table 2 of this form shall only be included if Criterion 2.2.3 (Contract Type B) of Section 3 (Evaluation and Qualification Criteria) is applicable.

Form EXP - 1: Contractual Experience

Fill out one (1) form per contract. Each contract shall be supported by Signed Contract Agreement.

Contractual Experience		
Contract No of	Contract Identification	
Award Date	Completion Date	
Role in Contract	<input type="checkbox"/> Manufacturer <input type="checkbox"/> Supplier <input type="checkbox"/> Subcontractor	
Total Contract Amount	\$	
If partner in a joint venture or subcontractor, specify participation of total contract amount	Percent of Total	Amount
Purchaser's name Address Telephone/Fax Number E-mail		
Description of the Similarity in Accordance with Criteria 2.2.1 (Contract Type A) or 2.3.1 (Contract Type B) of Section 3 (Evaluation and Qualification Criteria)		

- Note -

This form shall only be included if either Criterion 2.2.1 (Contract Type A) or 2.3.1 (Contract Type B) of Section 3 (Evaluation and Qualification Criteria) is applicable.

Form EXP - 2: Technical Experience

Fill out one (1) form per contract. Each contract shall be supported by Signed Contract Agreement.

Technical Experience	
Name of Product	
Manufacturer:	Address and Nationality:
Requirements in Accordance with Criterion 2.3.2 (Contract Type B) of Section 3 (Evaluation and Qualification Criteria)	
(i) Product has been in production for at least years.	
(ii) Product (or equipment) has been sold a minimum of units of similar type and specification over the last three (3) years.	
(iii) Product has been in operation for a minimum of years.	

- Note -

This form shall only be included if Criterion 2.3.2 (Contract Type B) of Section 3 (Evaluation and Qualification Criteria) is applicable. Add pages as necessary. The Purchaser reserves the right to verify authenticity of Bidder submissions.

Form EXP - 3: Production Capacity

Fill out one (1) form per product and manufacturer.

Production Capacity	
Name of Product	
Manufacturer:	Address and Nationality:
Requirements in Accordance with Criterion 2.3.3 (Contract Type B) of Section 3 (Evaluation and Qualification Criteria)	
Production facility 1 (include location):	
Production facility 2 (include location):	
Production facility 3 (include location):	

- Note -

This form shall only be included if Criterion 2.3.3 (Contract Type B) of Section 3 (Evaluation and Qualification Criteria) is applicable. The Purchaser reserves the right to verify authenticity of Bidder submissions.

Form FIN - 1: Historical Financial Performance

Each Bidder must fill out this form.

In case of a Joint Venture, each Joint Venture Partner must fill out this form separately and provide the Joint Venture Partner's name:

Joint Venture Partner: _____

Financial Data for Previous ___ Years [\$ Equivalent]		
Year 1:	Year 2:	Year ___:

Information from Balance Sheet

Total Assets (TA)			
Total Liabilities (TL)			
Net Worth = TA-TL			
Current Assets (CA)			
Current Liabilities (CL)			
Working Capital = CA - CL			

Most Recent Working Capital		To be obtained for most recent year and carried forward to FIN - 3 Line 1; in case of Joint Ventures, to the corresponding Joint Venture Partner's FIN - 3.
------------------------------------	--	---

Information from Income Statement

Total Revenues			
Profits Before Taxes			
Profits After Taxes			

- Attached are copies of financial statements (balance sheets including all related notes, and income statements) for the last _____ years, as indicated above, complying with the following conditions:
- 1) Unless otherwise required by Section 3 of the Bidding Documents, all such documents reflect the standalone financial situation of the legal entity or entities comprising the Bidder and not the Bidder's parent companies, subsidiaries, or affiliates.
 - 2) Historical financial statements must be audited by a certified accountant.
 - 3) Historical financial statements must be complete, including all notes to the financial statements.
 - 4) Historical financial statements must correspond to accounting periods already completed and audited (no statements for partial periods shall be requested or accepted).

- Note -

This form shall only be included if Criterion 2.3.1 (Contract Type A) or 2.4.1 (Contract Type B) of Section 3 (Evaluation and Qualification Criteria) is applicable.

Form FIN - 2: Size of Operation (Average Annual Turnover)

Each Bidder must fill out this form.

The information supplied should be the Annual Turnover of the Bidder or each partner of a Joint Venture for the total certified payments received from the clients for contracts in progress or completed, converted to US dollars at the rate of exchange at the end of the period reported.

In case of a Joint Venture, each Joint Venture Partner must fill out this form separately and provide the Joint Venture Partner's name:

Joint Venture Partner: _____

Annual Turnover Data for the Last 3 Years			
Year	Amount Currency	Exchange Rate	\$ Equivalent
Average Annual Turnover			

- Note -

This form shall only be included if Criterion 2.3.2 (Contract Type A) or 2.4.2 (Contract Type B) of Section 3 (Evaluation and Qualification Criteria) is applicable.

Form FIN - 3: Cash Flow Capacity

Specify proposed sources of financing, such as working capital, liquid assets,⁴ lines of credit, and other financial resources (other than any contractual advance payments) available to meet the cash flow requirements indicated under Criterion 2.4.3 (Contract Type B) of Section 3 (Evaluation and Qualification Criteria).

Financial Resources		
No.	Source of financing	Amount (\$ equivalent)
1		
2		
3		

- Note -

This form shall only be included if Criterion 2.4.3 (Contract Type B) of Section 3 (Evaluation and Qualification Criteria) is applicable.

⁴ Liquid assets mean cash and cash equivalents, short-term financial instruments, short-term available-for-sale-securities, marketable securities, trade receivables, short-term financing receivables, and other assets that can be converted into cash within one (1) year.

Section 5: Eligible Countries

- | | |
|--------------------------------|------------------------------------|
| 1. Afghanistan | 34. Federated States of Micronesia |
| 2. Armenia | 35. Mongolia |
| 3. Australia | 36. Myanmar |
| 4. Austria | 37. Nauru |
| 5. Azerbaijan | 38. Nepal |
| 6. Bangladesh | 39. The Netherlands |
| | 40. New Zealand |
| | 41. Niue |
| 7. Bhutan | 42. Norway |
| 8. Brunei Darussalam | 43. Pakistan |
| 9. Cambodia | 44. Palau |
| 10. Canada | 45. Papua New Guinea |
| 11. People's Republic of China | 46. Philippines |
| 12. Cook Islands | 47. Portugal |
| 13. Denmark | 48. Samoa |
| 14. Fiji | 49. Singapore |
| 15. Finland | 50. Solomon Islands |
| 16. France | 51. Spain |
| 17. Georgia | 52. Sri Lanka |
| 18. Germany | 53. Sweden |
| 19. Hong Kong, China | 54. Switzerland |
| 20. India | 55. Taipei, China |
| 21. Indonesia | 56. Tajikistan |
| 22. Ireland | 57. Thailand |
| 23. Italy | 58. Timor-Leste |
| 24. Japan | 59. Tonga |
| 25. Kazakhstan | 60. Türkiye |
| 26. Kiribati | 61. Turkmenistan |
| 27. Republic of Korea | 62. Tuvalu |

- 28. Kyrgyz Republic
- 29. Lao PDR
- 30. Luxembourg
- 31. Malaysia
- 32. Maldives
- 33. Marshall Islands

- 63. United Kingdom
- 64. United States
- 65. Uzbekistan
- 66. Vanuatu
- 67. Viet Nam

Section 6: Schedule of Supply

Contents

1. List of Goods and Related Services	6-84
2. Delivery and Completion Schedule.....	6-90
3. Technical Specifications	6-95
4. Drawings	6-189

1. List of Goods and Related Services

Lot 1: Automobile (Hybrid)			
Item No.	Item Description	Unit of Measurement	Quantity
1	Hybrid Vehicle	Nos	1

Lot 2: Automobile Transmission Vehicle			
Item No.	Name of Goods or Related Services	Unit of Measurement	Quantity
1	Auto Transmission Vehicle	Nos	1
2	Continuously Variable Transmission	Nos	2

Lot 3 Measuring Equipment

Item No.	Item Description	Unit of Measurement	Quantity (A)
1.	Ammeter	Nos	2
2.	Clampmeter	Nos	10
3.	Pen Style Voltage- Probe	Nos	20
4.	Specific gravity meter	Nos	4
5.	Engineer's Square	Nos	6
6.	Small Hole Gauge Set	Set	4
7.	Cooling System Analyser	Set	1
8.	Engine Compression Tester for petrol engine	Set	2
9.	Metric Torque Wrench with 40-200Nm range	Nos	4
10.	Outside Micrometer _(50-75mm)	Nos	10

Bidding Document for G-13 Procurement of Automobile Tools and Equipment (Lot 1-8)

11.	Outside Micrometer (75-100mm)	Nos	10
12.	Vernier Caliper (300mm)	Nos	7
13.	Drive Belt Tension Gauge	Nos	4
14.	Fuel Pressure Gauge	Set	4
15.	Plasti gauge set	Set	20
16.	Cylinder Bore Gauge	Set	10
17.	Straight Edge	Nos	6
18.	Telescopic Gauge set	Set	10
19.	Milli-ohm meter CAT-IV	Nos	2
20.	High voltage two-pole tester	Nos	2
21.	4-wheel Alignment Set & Lift	Set	2
22.	Armature Growler	Nos	4
23.	Alternator / Starter Motor Test Bench	Nos	2
24.	High Rate Discharge Tester	Nos	2
25.	Automotive Oscilloscope	Nos	1
26.	Automotive Air-Conditioner Leakage Detector	Nos	1

Lot 4-Automobile Repair Tools

Item No.	Description	Unit of Measurement	Quantity (A)
1.	Suspension Arm Bushing Service Kit	Set	2
2.	MacPherson Strut Vise	Nos	2
3.	Disc and Drum Brake Service Set	Set	4
4.	Vacuum Operated Hydraulic Brake Bleeding Kit	Set	4
5.	Wire Stripper	Nos	12
6.	Bearing Pullers	Set	2
7.	Internal (Gear) Puller	Set	2
8.	Set, Assortment of Tools (Metric):	Set	10
9.	Oil Filter Removal Cup Wrench Set, in a Protective Box	Set	2
10.	7-Drawer Tool Trolley with Lock	Nos	10
11.	Valve Guide Driver/removal tools Set	Set	4
12.	Valve Guide Reamer Set	Set	4
13.	Vee-Blocks	Set	2
14.	Bearing Race & Seal Driver Set	Set	2
15.	Swivel joint spanner set	Set	6
16.	Portable Battery Power Screwdriver	Set	6
17.	Heat shrink blower	Nos	4
18.	Blind hole pulley kit	Set	4

Bidding Document for G-13 Procurement of Automobile Tools and Equipment (Lot 1-8)

Lot 5-Automobile Equipment

Item No.	Description	Unit of Measurement	Quantity (A)
1.	Parts Washer	Nos	4
2.	Headlight Aimer	Nos	1
3.	5-Gas Vehicle Emissions Analyser	Nos	1
4.	Diesel Smoke Meter	Nos	1
5.	Recycling/Recharging Refrigerant Machine	Nos	1
6.	Electronic Ignition Analyser	Nos	2
7.	Hand Operated Vacuum Pump	Set	2
8.	Scissors Hoist	Nos	2
9.	2 Posts Electro-Hydraulic Hoist	Nos	1
10.	Compressed Air Hose Reels - ceiling hung	Nos	8
11.	Exhaust Extraction Hose Reels	Nos	4
12.	Hydraulic Jack - Lifting capacity up to 2000 kg	Nos	5
13.	Safety Stand	Set	6
14.	Waste Fluid / Oil Collection Tank	Nos	2
15.	Forklift	Nos	1
16.	Pallet jack	Nos	1
17.	Portable Surface Table	Nos	2
18.	Air compressor	Nos	1

Bidding Document for G-13 Procurement of Automobile Tools and Equipment (Lot 1-8)

19.	Power Compression Crimping Tools	Set	1
20.	Automatic Transmission Diagnostic Set	Set	1

Lot 6-Automobile Simulator

Item No.	Description	Unit of Measurement	Quantity (A)
1.	Air Bag Simulator	Nos	1
2.	Analog and Digital Trainer Kit	Set	1
3.	Electricity Master	Set	1
4.	Spark Ignition Engine Management System Model	Nos	1
5.	Common Rail Fuel System simulator	Nos	1
6.	Four-stroke SI engine cut-away model	Nos	1
7.	Four-stroke Diesel engine cut-away model	Nos	1
8.	Two-stroke engine cut-away model	Nos	1
9.	Final drive and differential cut-away model	Nos	1

Lot 7-Automobile parts

Item No.	Description	Unit of Measurement	Quantity (A)
1.	Light Vehicle Automatic Transmission Assembly (Front Wheel Drive)	Nos	1
2.	Light Vehicle All-Wheel Drive Transmission	Nos	1
3.	Automatic Transmission (Rear Wheel Drive)	Nos	1
4.	Supercharger	Nos	1

Lot 8 Furniture

Item No.	Description	Unit of Measurement	Quantity (A)
1.	Steel Cabinet, Full Height	Nos	6
2.	Students' Lab benches	Nos	18
3.	Storage Rack	Nos	10

Delivery and Completion Schedule

The delivery period shall start as of the supply order date.

Lot 1: Automobile (Hybrid)				
Item No.	Item Description	Delivery Schedule (Duration)	Location	Required Arrival Date of Goods
1	Hybrid Vehicle	24 weeks	TTI-Thimphu (Serbithang)	Within 24 weeks from the date of supply order.

Lot 2: Automobile Transmission Vehicle				
Item No.	Name of Goods or Related Services	Delivery Schedule (Duration)	Location	Required Arrival Date of Goods
1	Auto Transmission Vehicle	24 weeks	Item no.1 to delivered to TTI-Thimphu. Item no. 2 to be delivered 1 each to TTI Thimphu and TTI-Samthang.	Within 24 weeks from the date of supply order.
2	Continuously Variable Transmission			

Lot 3 Measuring Equipment

Item No.	Item Description	Delivery Schedule (Duration)	Location	Required Arrival Date of Goods
1	Ammeter	24 weeks	All the items to be delivered to TTI-Thimphu. Except item no 21, 22 and 23 to be delivered one each to TTI-Thimphu	Within 24 weeks from the date of supply order
2	Clampmeter			
3	Pen Style Voltage- Probe			
4	Specific gravity meter			
5	Engineer's Square			
6	Small Hole Gauge Set			
7	Cooling System Analyser			
8	Engine Compression Tester for Petrol Engine			
9	Metric Torque Wrench with 40-200Nm range			
10	Outside Micrometer _(50-75mm)			

Bidding Document for G-13 Procurement of Automobile Tools and Equipment (Lot 1-8)

11	Outside Micrometer (75-100mm)	and TTI-Samthang.	
12	Vernier Caliper (300mm)		
13	Drive Belt Tension Gauge		
14	Fuel Pressure Gauge		
15	Plastic gauge set		
16	Cylinder Bore Gauge		
17	Straight Edge		
18	Telescopic Gauge set		
19	Milli-ohm meter CAT-IV		
20	High voltage two-pole tester		
21	4-wheel Alignment Set & Lift		
22	Armature Growler		
23	Alternator / Starter Motor Test Bench		
24	High Rate Discharge Tester		
25	Automotive Oscilloscope		
26	Automotive Air-Conditioner Leakage Detector		

Lot 4-Automobile Repair Tools

Item No.	Description	Delivery Schedule (Duration)	Location	Required Arrival Date of Goods
1	Suspension Arm Bushing Service Kit	24 weeks	TTI-Thimphu (Serbithang)	Within 24 weeks from the date of supply order
2	MacPherson Strut Vise			
3	Disc and Drum Brake Service Set			
4	Vacuum Operated Hydraulic Brake Bleeding Kit			
5	Wire Stripper			
6	Bearing Pullers			
7	Internal (Gear) Puller			
8	Set, Assortment of Tools (Metric):			

Bidding Document for G-13 Procurement of Automobile Tools and Equipment (Lot 1-8)

9	Oil Filter Removal Cup Wrench Set, in a Protective Box			
10	7-Drawer Tool Trolley with Lock			
11	Valve Guide Driver Set			
12	Valve Guide Reamer Set			
13	Vee-Blocks			
14	Bearing Race & Seal Driver Set			
15	Swivel joint spanner set			
16	Portable Battery Power Screwdriver			
17	Heat shrink blower			
18	Blind hole pulley kit			

Lot 5-Automobile Equipment

Item No.	Description	Delivery Schedule (Duration)	Location	Required Arrival Date of Goods
1	Parts Washer	24 weeks	All the items to be delivered to TTI-Thimphu. Except item no 9 and 15 to be delivered to TTI-Samthang.	Within 24 weeks from the date of supply order
2	Headlight Aimer			
3	5-Gas Vehicle Emissions Analyser			
4	Diesel Smoke Meter			
5	Recycling/Recharging Refrigerant Machine			
6	Electronic Ignition Analyser			
7	Hand Operated Vacuum Pump			
8	Scissors Hoist			
9	2 Posts Electro-Hydraulic Hoist			
10	Compressed Air Hose Reels - ceiling hung			
11	Exhaust Extraction Hose Reels			
12	Hydraulic Jack - Lifting capacity up to 2000 kg			
13	Safety Stand			

Bidding Document for G-13 Procurement of Automobile Tools and Equipment (Lot 1-8)

14	Waste Fluid / Oil Collection Tank		
15	Forklift		
16	Pallet jack		
17	Portable Surface Table		
18	Air compressor		
19	Power Compression Crimping Tools		
20	Automatic Transmission Diagnostic Set		

Lot 6-Automobile Simulator

Item No.	Description	Delivery Schedule (Duration)	Location	Required Arrival Date of Goods
1	Air Bag Simulator	24 weeks	TTI- Thimphu (Serbithang)	Within 24 weeks from the date of supply order
2	Analog and Digital Trainer Kit			
3	Electricity Master			
4	Spark Ignition Engine Management System Model			
5	Common Rail Fuel System simulator			
6	Four-stroke SI engine cut-away model			
7	Four-stroke Diesel engine cut-away model			
8	Two-stroke engine cut-away model			
9	Final drive and differential cut-away model			

Lot 7-Automobile parts

Item No.	Description	Delivery Schedule (Duration)	Location	Required Arrival Date of Goods
1	Light Vehicle Automatic Transmission Assembly (Front Wheel Drive)	24 weeks	TTI- Thimphu (Serbithang)	Within 24 weeks from the date of supply order
2	Light Vehicle All-wheel drive Transmission			
3	Automatic Transmission (rear-wheel drive)			
4	Supercharger			

Lot 8 Furniture

Item No.	Description	Delivery Schedule (Duration)	Location	Required Arrival Date of Goods
1	Steel Cabinet, Full Height	24 weeks	TTI- Thimphu (Serbithang)	Within 24 weeks from the date of supply order
2	Students' Lab benches			
3	Storage Rack			

Technical Specifications

Lot 1-Automobile (Hybrid)

1. Hybrid Vehicle

Features	Required	Complied	Bidder's specifications
		(Yes/No)	(Please attach the original brochures)
Make and Model			
Country of Origin			
Technical Specification and Minimum Requirements	<p>Hybrid System and Technology :</p> <ul style="list-style-type: none"> -Hybrid Electric Vehicle -Self Battery Charging -System Combined Max Power: 90 -95 kW -Electric Drive Motor : AC Synchronous (Permanent Magnet) -Max Power: 80 - 85 kW -Max Torque: 250 - 255 Nm <p>Electric Generation Motor :</p> <ul style="list-style-type: none"> -AC Synchronous (Permanent Magnet type) -Max Power: 70 - 75 kW <p>Engine :</p> <ul style="list-style-type: none"> -Petrol-operated -Water Cooled Inline 4 Cylinder VTEC, DOHC -16 Number of valves -Displacement: 1400 - 1500 cm3 -Max Power: 70 - 75 kW -Max Torque: 120 - 130 Nm -Petrol tank capacity: 35 - 45 litter <p>Hybrid Battery :</p> <ul style="list-style-type: none"> -Nominal Voltage: 170 -175V -Battery Cell type: Lithium-ion <p>Transmission :</p> <ul style="list-style-type: none"> -Electrically-coupled Continuously Variable - Transmission <p>Dimensions :</p> <ul style="list-style-type: none"> -Overall Length: 4500 - 4600 mm -Overall Width: 1700 - 1750 mm -Overall Height: 1450 - 1500 mm -Wheelbase: 2550 -2650 mm 		

Bidding Document for G-13 Procurement of Automobile Tools and Equipment (Lot 1-8)

	<p>Suspension System: -Front McPherson Strut with Coil Spring -Rear Torsion Beam with Coil Spring</p> <p>Brake System: -Front Ventilated Disc -Rear Solid Disk -Electric Parking Brake System -Electric Regenerative Braking System -Anti-Lock Brake System</p> <p>Tyres and Wheels: -15 - 17 inch Alloy</p> <p>Colours: -Any</p> <p>Accessory: -Keyless Remote x2 -Automobile Repair manual (OPTIONAL) -Wiring diagram (OPTIONAL) (OPTIONAL) -Owner's manual -Spare tyre or puncture repair kit</p>		
Other Requirements	Minimum 24 months warranty		

Lot 2-Automatic transmission Vehicle

1. Auto Transmission Vehicle

Features	Required	Complied	Bidder's specifications
		(Yes/No)	(Please attach the original brochures)
Make and Model			
Country of Origin			
Technical Specification and Minimum Requirements	<p>Engine: -Petrol-operated -Water Cooled Inline 4 Cylinder, SOHC, VTEC -16 Number of valves -Displacement: 1100 - 1200 cm³ -Max Power: 60 - 70 kW -Max Torque: 100 - 120 Nm -Petrol tank capacity: 30 - 40 litter</p> <p>Transmission : -Continuously Variable Transmission</p>		

Bidding Document for G-13 Procurement of Automobile Tools and Equipment (Lot 1-8)

	<ul style="list-style-type: none"> -Shift position Indicator -Paddle Shift <p>Dimensions and Weight :</p> <ul style="list-style-type: none"> -Overall Length: 3900 - 4000 mm -Overall Width: 1650 - 1750 mm -Overall Height: 1450 - 1550 mm -Wheelbase: 2400 -2500 mm <p>Suspension System:</p> <ul style="list-style-type: none"> -Front McPherson Strut with Coil Spring -Rear Torsion Bar with Coil Spring <p>Brake System:</p> <ul style="list-style-type: none"> -Front Disc -Rear Drum -Anti-Lock Brake System <p>Tyres and Wheels:</p> <ul style="list-style-type: none"> -14 - 16 inch Alloy <p>Other Features:</p> <ul style="list-style-type: none"> -Front Dual Airbags -Automatic Climate Control -Speed sensing Auto Door Lock <p>Colours:</p> <ul style="list-style-type: none"> -Any <p>Accessory:</p> <ul style="list-style-type: none"> -Keyless Remote x2 -Repair manual (OPTIONAL) -Wiring diagram (OPTIONAL) -Owner's manual -Spare tyre or puncture repair kit 		
Other Requirements	Minimum 24 months warranty		

2. Continuously Variable Transmission

Features	Required	Complied	Bidder's specifications
		(Yes/No)	(Please attach the original brochures)
Make and Model			

Country of Origin			
Technical Specification and Minimum Requirements	<p>Features:</p> <ul style="list-style-type: none"> -Must be compatible with transmission assembly with item number 1 under Lot 2-Automatic transmission vehicles. -Continuously Variable Transmission -Front Engine, Front Drive Type 		
Other Requirements	Minimum 24 months warranty		

Lot 3 Measuring Equipment

1. Ammeter

Features	Required	Complied	Bidder's specifications
		(Yes/No)	(Please attach the original brochures)
Make and Model			
Country of Origin			
Technical Specification and Minimum Requirements	<p>Features:</p> <ul style="list-style-type: none"> -Measurement accuracy: Class 1.5 with front zero-point regulator. -Overload range of 100% with current meter for start-up bridging. <p>Standards:</p> <ul style="list-style-type: none"> -DIN 43700; EN 61010; VDE 0411; IEC 1010. <p>Specifications:</p> <ul style="list-style-type: none"> -Maximum Value: 80 Ampere. -Measurable Current Type: AC. <p>Accessory:</p> <ul style="list-style-type: none"> -Pre-mounted, replaceable scale. -Mounting frame, terminal cover. 		
Other Requirements			

2. Clampmeter

Features	Required	Complied	Bidder's specifications
		(Yes/No)	(Please attach the original brochures)

Make and Model			
Country of Origin			
Technical Specification and Minimum Requirements	<p>Features:</p> <ul style="list-style-type: none"> -True RMS. -Measurable AC current: 0.1A~600A. -ACV & Resistance measurement. -Data hold function. -Continuity check buzzer. <p>Specifications:</p> <ul style="list-style-type: none"> - ACA function: Range 199.9 / 600A, Accuracy $\pm(2\%+5)$, Resistance 0.1A. - ACV function: Range 199.9 / 600A, Accuracy $\pm(1.5\%+5)$, Resistance 0.1V. - Resistance function: Range, Accuracy $\pm(1.0\%+8)$, 0.1Ω. - Continuity function: Buzzer sounds at less than 100 Ω. <ul style="list-style-type: none"> -Sampling rate: 2 times / sec. -Display: 1999 count. -Range selection: Auto. -Operation temperature: 0 - 40°C. <p>Safety Standards:</p> <ul style="list-style-type: none"> - IEC61010-1, IEC61010-2-030 CAT.III 300V / II 600V. IEC61010-2-032, IEC61010-2-033, IEC61010-31 <ul style="list-style-type: none"> -Bandwidth: 50 - 400Hz. -Clamp diameter / contactor size: 25mm / 10 × 30mm. <p>Item Size:</p> <ul style="list-style-type: none"> -Length: 20 - 30 mm -Width: 45 - 55 mm -Height: 180 - 190 mm -Weight: 200 -220 g <p>Accessory:</p> <ul style="list-style-type: none"> -Test leads -Carrying case -Instruction manual -Battery 		

			
Other Requirements			

3. Pen Style Voltage- Probe

Features	Required	Complied	Bidder's specifications
		(Yes/No)	(Please attach the original brochures)
Make and Model			
Country of Origin			
Technical Specification and Minimum Requirements	<p>Features:</p> <ul style="list-style-type: none"> -Tests for voltage in 6 and 12 volt systems. Ground clip and touch probe to point being tested. -Tester bulb will light if power is present. 		
Other Requirements			

4. Specific gravity meter

Features	Required	Complied	Bidder's specifications
----------	----------	----------	-------------------------

		(Yes/No)	(Please attach the original brochures)
Make and Model			
Country of Origin			
Technical Specification and Minimum Requirements	<p>Features: -The specific gravity meter uses light refraction to test the freezing limit temperature of the engine coolant, the specific gravity of the battery fluid and the state of charge.</p> <p>Specifications: -Battery specific gravity: -Measuring range 1.15 - 1.3 sg (minimum scale 0.01 sg).</p> <p>-Engine coolant: -Measuring fluid Ethylene glycol/Propylene glycol -Measuring range: -50~0°C -Minimum scale: 5°C</p> <p>Accessory: -0-point calibration driver -Syringe -Cleaning cloth -Carrying case -Instruction manual</p> 		
Other Requirements	12 months warranty		

5. Engineer's Square

Features	Required	Complied	Bidder's specifications
		(Yes/No)	(Please attach the original brochures)
Make and Model			
Country of Origin			
Technical Specification and Minimum Requirements	<p>Features:</p> <ul style="list-style-type: none"> -Stainless steel -The non-disassemble measure part and the weight part are connected by a precise 90° L-shape. -The vertical measuring section can measure millimeters. <p>Item Size:</p> <ul style="list-style-type: none"> -150 x 100 mm 		
Other Requirements	12 months warranty		

6. Small Hole Gauge Set

Features	Required	Complied	Bidder's specifications
		(Yes/No)	(Please attach the original brochures)
Make and Model			
Country of Origin			

Bidding Document for G-13 Procurement of Automobile Tools and Equipment (Lot 1-8)

<p>Technical Specification and Minimum Requirements</p>	<p>Features: -Material: Hardened Steel -Finish: Stain -Measuring Range: 0.125 to 0.200", 0.200 to 0.300", 0.300 to 0.400", 0.400 to 0.500" -Number of Pieces: 4</p> 		
<p>Other Requirements</p>	<p>12 months warranty</p>		

7. Cooling System Analyser

Features	Required	Complied	Bidder's specifications
		(Yes/No)	(Please attach the original brochures)
<p>Make and Model</p>			
<p>Country of Origin</p>			
<p>Technical Specification and Minimum Requirements</p>	<p>Features: -Quickly and easily for testing leakage in the radiator system. -Vacuum leakage test and bubble-free refilling. -Quick-release coupling on each connection. - Japan type air jack</p>  <p>Contents: -Special pick hook (2 types of needle hose remover) -Adjustable Jaw</p>		

	<ul style="list-style-type: none"> -Manual pressure pump with pressure gauge -Pressure gauge with coolant hose, radiator hose fitting -Rubber cones with functional diameter 17~40mm. -Rubber hose -Caring case 		
Other Requirements	<ul style="list-style-type: none"> Instructional manual 12 months warranty 		

8. Engine Compression Tester for petrol engine

Features	Required	Complied	Bidder's specifications
		(Yes/No)	(Please attach the original brochures)
Make and Model			
Country of Origin			
Technical Specification and Minimum Requirements	<p>Features:</p> <ul style="list-style-type: none"> -Suitable for petrol engines on lawn mowers, motorbikes, cars, trucks and so on. -Gauge has dual colour scale with 0-300 PSI, 0-20 Kpa -Pressure release button on side of tester -Brass corrosion resistant fittings <p>Contents:</p> <ul style="list-style-type: none"> -Pressure gauge with pressure release button. - 6 pcs of attachment -Carrying case 		

			
Other Requirements	Company manufacturers instructional manual 12 months warranty		

9. Metric Torque Wrench with 40-200Nm range

Features	Required	Complied	Bidder's specifications (Please attach the original brochures)
		(Yes/No)	
Make and Model			
Country of Origin			
Technical Specification and Minimum Requirements	<p>Features:</p> <ul style="list-style-type: none"> -Quick release button with adjustable locking system, aluminum or steel handle with anodic treatment. -Tensile load depends on tightening torque applied to the fastener and the friction coefficient. <p>Specification:</p> <ul style="list-style-type: none"> - ½ inch drive attachment. - Ratchet mechanism head. - 40-200 Nm range. - ISO 9001 certified 		
Other Requirements	12 months warranty		

10. Outside Micrometer (50-75mm)

Features	Required	Complied	Bidder's specifications
		(Yes/No)	(Please attach the original brochures)
Make and Model			
Country of Origin			
Technical Specification and Minimum Requirements	<p>Features:</p> <ul style="list-style-type: none"> - Outside type Micrometer -Measurable range: 50 - 75mm, 0.01mm graduation - Accuracies standard DIN-863 or equivalent. - Ratchet stop for accurate repetitive readings. -Locking clamp. -Laser Marked graduation <p>Contents:</p> <ul style="list-style-type: none"> - Inspection certificate. - Carry case -Adjuster -Calibration rod 		
Other Requirements	12 months warranty		

11. Outside Micrometer (75-100mm)

Features	Required	Complied	Bidder's specifications
		(Yes/No)	(Please attach the original brochures)
Make and Model			
Country of Origin			

<p>Technical Specification and Minimum Requirements</p>	<p>Features:</p> <ul style="list-style-type: none"> - Outside type Micrometer -Measurable range: 75 - 100 mm, 0.01mm graduation - Accuracies standard DIN-863 or equivalent. - Ratchet stop for accurate repetitive readings. -Locking clamp. -Laser Marked graduation <p>Contents:</p> <ul style="list-style-type: none"> - Inspection certificate. - Carry case -Adjuster -Calibration rod 		
<p>Other Requirements</p>	<p>12 months warranty</p>		

12. Vernier Caliper (300mm)

Features	Required	Complied	Bidder's specifications
		(Yes/No)	(Please attach the original brochures)
<p>Make and Model</p>			
<p>Country of Origin</p>			
<p>Technical Specification and Minimum Requirements</p>	<p>Features:</p> <ul style="list-style-type: none"> - Standard type vernier caliper -Measurable range: 300 mm, 0.02mm graduation -Rotating dial with lock for easy zero setting. -Shockproof and smooth sliding. <ul style="list-style-type: none"> -Made of fully hardened, tempered, stainless steel. -Locking screw: Non detachable and Thumb roller for easy movement. 		

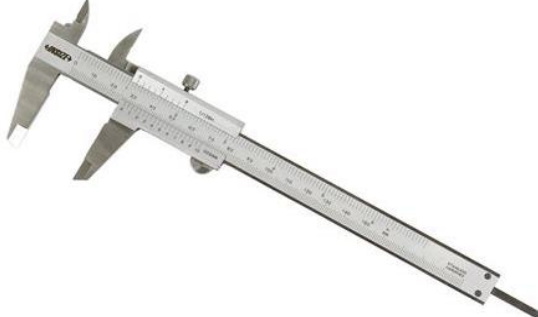
	<ul style="list-style-type: none"> -Laser Marked graduation -Accuracies standard DIN-863 or equivalent. <p>Contents:</p> <ul style="list-style-type: none"> - Inspection certificate. - Carry case 		
Other Requirements	12 months warranty		

13. Drive Belt Tension Gauge

Features	Required	Complied	Bidder's specifications
		(Yes/No)	(Please attach the original brochures)
Make and Model			
Country of Origin			
Technical Specification and Minimum Requirements	<p>Features:</p> <ul style="list-style-type: none"> -Drive belt tension gauge for serpentine and V-belts. -Tension is measured by a release handle and a mechanism that clamps the belt. -Scale reads 30 -180 lbs or equivalent. -Accuracies standard DIN-863 or equivalent. 		
Other Requirements	12 months warranty Company manufacturer instructional manual		

Bidding Document for G-13 Procurement of Automobile Tools and Equipment (Lot 1-8)

14. Fuel Pressure Gauge

Features	Required	Complied	Bidder's specifications
		(Yes/No)	(Please attach the original brochures)
Make and Model			
Country of Origin			
Technical Specification and Minimum Requirements	<p>Features:</p> <ul style="list-style-type: none"> -Universal design fittings and hoses cover all fuel injection systems and most cars. -0-140 PSI /0-10 bar scale. -Anti-corrosion material <p>Contents:</p> <ul style="list-style-type: none"> - 1x 3-1/2inches big dial pressure gauge. - 1x 14inchesL long hose with 1/4inches Female brass parts. - 1x 8inchesL short hose with 1/4inches Male x M6 brass parts. - 1x T type parts (Aluminum tee parts 1/4inches & 3/8inches barbed x 1/8inches-24NPT & brass parts 1/8inches-27NPT x 1/4inches-18NPT). - 13x Brass parts. - 1x Hose (1/4inches x 3-1/2inchesL). - 1x Hose (3/8inches x 3-1/2inchesL). - 2x Hose clamps. - 1x Instruction. - 1x Carrying case. 		
Other Requirements	<ul style="list-style-type: none"> -12 months warranty -Company manufacturers instructional manual 		

15. Plasti gauge kit

Bidding Document for G-13 Procurement of Automobile Tools and Equipment (Lot 1-8)

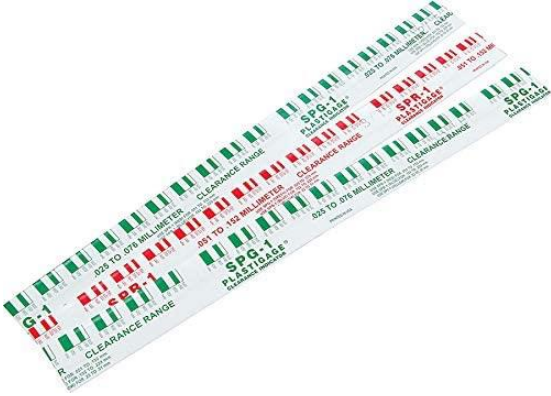
Features	Required	Complied	Bidder's specifications
		(Yes/No)	(Please attach the original brochures)
Make and Model			
Country of Origin			
Technical Specification and Minimum Requirements	<p>Features:</p> <p>-Gauges for measuring the gap between crankshaft and metal. or to check oil clearance</p> <p>Contents:</p> <p>-0.025 to 0.76 milli meter set. -0.051 to 0.152 milli meter set.</p> 		

16. Cylinder Bore Gauge

Features	Required	Complied	Bidder's specifications
		(Yes/No)	(Please attach the original brochures)
Make and Model			
Country of Origin			
Technical Specification and Minimum Requirements	<p>Features:</p> <p>-The moveable anvil on one side and an interchangeable on another side , which serves for setting the bore diameters.</p> <p>-Measuring Ranges: 50-160mm graduation 0.01mm.</p>		

Bidding Document for G-13 Procurement of Automobile Tools and Equipment (Lot 1-8)

	<p>Contents:</p> <ul style="list-style-type: none"> - At least five measuring anvils. - Thickness adjustment shims (0.5, 1, 2, 3 mm). - Dial gauge. - Steel or alloy clamping shaft. - Carrying case. 		
Other Requirements	<p>12 months warranty Company manufacturer instructional manual</p>		

17. Straight Edge

Features	Required	Complied	Bidder's specifications
		(Yes/No)	(Please attach the original brochures)
Make and Model			
Country of Origin			
Technical Specification and Minimum Requirements	<p>Features:</p> <ul style="list-style-type: none"> -Material: Alloy steel. - Accuracy: ± 0.001 inch. <p>Item size:</p> <ul style="list-style-type: none"> - Length: 36inch. - Width: 0.25 - 1 inch. - Height/Thickness: 1.5 - 3.5 inch. 		
Other Requirements	<p>ISO 9001 certified 12 months warranty</p>		

18. Telescopic Gauge set

Features	Required	Complied	Bidder's specifications
		(Yes/No)	(Please attach the original brochures)
Make and Model			
Country of Origin			
Technical Specification and Minimum Requirements	<p>Features:</p> <ul style="list-style-type: none"> - Spring-loaded plunger extends in the bore (or groove) to determine the inside diameter (or groove width). - With knurled clamps. <p>Contents:</p> <ul style="list-style-type: none"> - 8-12.7mm Gauge x1. - 12.7 -19mm Gauge x1. - 19 - 32mm Gauge x1. -32 -54 mm Gauge x1. - 54 - 90 mm Gauge x1. - 90 - 150 mm Gauge x1. 		
Other Requirements	12 months warranty ISO9001 certified		

19. Milli-ohm meter CAT-IV

Features	Required	Complied	Bidder's specifications
		(Yes/No)	(Please attach the original brochures)
Make and Model			
Country of Origin			

<p>Technical Specification and Minimum Requirements</p>	<p>Features:</p> <ul style="list-style-type: none"> - Accurate four terminal measurement down to 100μ ohms does not require test leads resistance compensation. - Ranges from 200.0m ohms to 2000 ohms with minimum resolution of 100μ Ohm. - Measurement precision with three test currents with over-temperature protection. - Protection against inadvertent connection to overvoltage. - LCD display. - Potential lead resistance, current lead resistance checks. - Auto-hold and auto-off features. - Indicates measurement errors due to temperature or connection problems. - Battery powered. -IEC / EN 61010-1 or Equivalent <p>Contents:</p> <ul style="list-style-type: none"> - Test lead x 4. - Battery. 		
<p>Other Requirements</p>	<p>12 months warranty Company manufacturer instructional manual</p>		

20. High voltage two-pole tester

Features	Required	Complied	Bidder's specifications (Please attach the original brochures)
		(Yes/No)	
Make and Model			
Country of Origin			
Technical Specification	<p>Features:</p>		

<p>and Minimum Requirements</p>	<p>- Designed according to IEC EN 61243-3:2014 to verify the absence of voltage – even with discharged batteries. - CAT IV 600 V, CAT III 690 V safety rating With 4 ways to indicate the presence of voltage – LED indicator, LCD display, audible tone or tactile feedback, always know if hazardous voltage is present .</p> <p>Specifications: - Voltage: AC/DC 12V -690V. - Continuity: 0 - 400kΩ. - Frequency: 0 / 40 - 400 Hz. 200 kΩ input impedance Current draw 3,5mA at 690V and 1,15mA at 230V. -Safety rating CAT II 690V, CAT III 600V. -IP rating IP54.</p> <p>Contents: -Carrying case -Battery</p> <hr/> 		
<p>Other Requirements</p>	<p>12 months warranty Company manufacturer instructional manual</p>		

21. 4-wheel Alignment Set & Lift

Features	Required	Complied	Bidder's specifications
		(Yes/No)	(Please attach the original brochures)

Make and Model			
Country of Origin			
Technical Specification and Minimum Requirements	<p>Power sources:</p> <ul style="list-style-type: none"> -Input Voltage: AC220 - 230V Frequency 50Hz with B3 type, B3L type power plug or three-phase AC415V. <p>Features:</p> <ul style="list-style-type: none"> - 4 Wheel alignment machine with 4-post or scissor lift, suitable for passenger vehicles. - Target-aiming cameras are mounted on a pillar. <p>Camera Sensor mount size:</p> <ul style="list-style-type: none"> - Length 300 - 500 mm - Width 2600 - 2800 mm - Height 3000 - 3300 mm <p>Alignment Measuring functions:</p> <ul style="list-style-type: none"> -S.A.I and Included Angle -Set Back -Wheelbase Difference -Track Width Difference -Tread Width Difference -Lateral Offset -Rear Set Back -Axle Offset -Toe angle -Caster angle -Camber angle <p>Console PC Specification</p> <ul style="list-style-type: none"> - Desktop PC with Wheel Alignment Software - Windows OS 10 or 11 - Memory 4GB or more - Hard drive(SSD) 240 GB or more -24 inch or larger monitor <p>Alignment Software</p> <ul style="list-style-type: none"> - Perpetual license <p>Contents:</p> <ul style="list-style-type: none"> - Steering Wheel Holder - Brake Pedal Depressor - Wireless Remote - Power Line Filter - Wheel adapter with Wheel position Sensor x 4 -Equipment cover (console PC) -company manufacturers Instruction manual 		

			
Other Requirements	<ul style="list-style-type: none"> - After installation of the equipment, the supplier should check that the product is working. - Provide training on usage of the product within one month of installation of the product. - 12 months Warranty 		

22. Armature Growler

Features	Required	Complied	Bidder's specifications
		(Yes/No)	(Please attach the original brochures)
Make and Model			
Country of Origin			
Technical Specification and Minimum Requirements	<p>Power sources:</p> <ul style="list-style-type: none"> -Input Voltage: AC220 - 230V Frequency 50Hz with B3 type, B3L type power plug or three-phase AC415V. <p>Features:</p> <ul style="list-style-type: none"> -Armature short-circuit detection is possible. -Measurable armature dia: 20mm to 100mm. -Current gauge. -2 test probe. <p>Contents:</p> <ul style="list-style-type: none"> -Company manufacturer Instruction manual. 		
Other Requirements	12 months warranty		

Bidding Document for G-13 Procurement of Automobile Tools and Equipment (Lot 1-8)

23. Alternator / Starter Motor Test Bench

Features	Required	Complied	Bidder's specifications
		(Yes/No)	(Please attach the original brochures)
Make and Model			
Country of Origin			
Technical Specification and Minimum Requirements	<p>Power sources:</p> <ul style="list-style-type: none"> -Input Voltage: AC220 - 230V Frequency 50Hz with B3 type, B3L type power plug or three-phase AC415V. <p>Features:</p> <ul style="list-style-type: none"> - Suitable for testing the output of alternator and starter motor up to 3.5 kW. - Built-in AC voltage Stabilizer. - A heavy duty fast mounting jack for alternator. - MCBs and fuses for short circuit protection. - Vacuum testing arrangement. - DC supply for Alternator excitation. - 12V or 24 V DC source for automobile components inspection. -Ohmmeter for resistance check. -Voltmeter for regular saturation indication and W terminal voltage sensing meter for alternator. -150 Amps / 1000V bridge rectifier for 200 Amps testing facility for starter motor. -Screen. <p>Contents:</p> <ul style="list-style-type: none"> - Company manufacturer Instruction manual 		

			
<p>Other Requirements</p>	<p>After installation of the equipment, the supplier should check that the product is working. Provide training on usage of the product within one month of installation of the product. 12 months warranty</p>		

24. High Rate Discharge Tester

Features	Required	Complied	Bidder's specifications (Please attach the original brochures)
		(Yes/No)	
Make and Model			
Country of Origin			
<p>Technical Specification and Minimum Requirements</p>	<p>Features:</p> <ul style="list-style-type: none"> -Tests 6V, 12V batteries and 12V, 24V charging systems. - Test battery capacities from 40-2,000 CCA. - Presents State of Health and State of Charge percentage. - Integrated printer to capture test results and customer records. - Detachable test clamps for service and replacement. - Full charging system test with diode/ripple test. - Micro-load testing. <p>Contents:</p> <ul style="list-style-type: none"> -Instruction manual -Test cramp 		

	<p>-Carrying case -Battery -Print paper</p> 		
Other Requirements	12 months warranty		

25. Automotive Oscilloscope

Features	Required	Complied	Bidder's specifications
		(Yes/No)	(Please attach the original brochures)
Make and Model			
Country of Origin			
Technical Specification and Minimum Requirements	<p>Power sources: -Input Voltage: AC220 - 230V Frequency 50Hz with B3 type, B3L type power plug.</p> <p>Features: Display size 4 - 5 inch, adjustable contrast.</p> <p>Test functions: -Engine tests function (RPM 600rpm - 15,000rpm) -Ignition coil Primary voltage: 0 to 300V. -Ignition coil Secondary voltage: 0 to 80kV. -Burn time: 0.6 ms to 5ms. -Burn voltage: 0 to 80kV. -Relative Compression 0 to -100% contribution. - Alternator Ripple Voltage 0 to 300V. - Battery Condition Test 0 to 40V. - Fuel Injection Pulse Width 0 to 1800 ms.</p> <p>Sensors test function:</p>		

Bidding Document for G-13 Procurement of Automobile Tools and Equipment (Lot 1-8)

	<ul style="list-style-type: none"> - Inspect Mass Air Flow Sensor (MAF) - Inspect Manifold Absolute Pressure (MAP) - Inspect Oxygen Sensor (Zirconium and Titanium) - Inspect Dual Oxygen Sensor - Inspect Temperature Sensors - Inspect Position Sensors such as Camshaft Position - Inspect Exhaust Gas Recirculation (EGR) - Inspect Ride Height Sensors - Inspect Magnetic Sensors - Inspect Speed Sensors - Inspect Knock Sensors - Inspect Distributor Triggering <p>Air / fuel system test function:</p> <ul style="list-style-type: none"> -Mixture Control (Feedback) -Frequency Control Valve (CIS E) -Air Flow Meter -Idle Air Compensation -Exhaust Gas Recirculation (EGR) <p>Electrical system test function:</p> <ul style="list-style-type: none"> -Battery Condition Test -Charging -Diode Test -Field Control -Ripple Voltage Measurement -Cranking -Voltage Reference And Ground -Voltage Drop -Clamping Diode -Solenoid Tests -Stepper Motor <p>Contents:</p> <ul style="list-style-type: none"> -Oscilloscope -Oscilloscope type test probe (more than two pieces) -Test lead (more than two pieces) -Alligator clip (more than two pieces) -Charger (AC adapter) -Carrying case -Instruction manual 		
--	---	--	--

				
Other Requirements	12 months warranty			

26. Automotive Air-Conditioner Leakage Detector

Features	Required	Complied	Bidder's specifications (Please attach the original brochures)
		(Yes/No)	
Make and Model			
Country of Origin			
Technical Specification and Minimum Requirements	<p>Features:</p> <ul style="list-style-type: none"> -Refrigerant gas leak detection of CFCs, HFCs, HCFCs, and blends from 100 ppm to 3000 ppm. -High (100 to 1000 ppm) and low (200 to 3000 ppm) levels of sensitivity settings; based on R-134A. -Automatic zero-point calibration at power-up, hold, mute, and low battery functions. -Conforms to EN14624 or equivalent <p>Contents:</p> <ul style="list-style-type: none"> - Battery -Carrying case -Instruction manual 		

			
Other Requirements	12 months warranty		

Lot 4-Automobile Repair Tools

1. Suspension Arm Bushing Service Kit

Features	Required	Complie d	Bidder's specifications
		(Yes/No)	(Please attach the original brochures)
Make and Model			
Country of Origin			
Technical Specification and Minimum Requirements	<ul style="list-style-type: none"> • Bushing Driver Set • 10mm to 42mm in diameter and 3/8 inch to 1-3/8 inch in diameter, 30 - 33 pcs <p>Contents:</p> <ul style="list-style-type: none"> -Carrying case -Company instruction manual 		

Bidding Document for G-13 Procurement of Automobile Tools and Equipment (Lot 1-8)

Other Requirements	-12 months warranty		
--------------------	---------------------	--	--

2. MacPherson Strut Vice

Features	Required	Complied	Bidder's specifications (Please attach the original brochures)
		(Yes/No)	
Make and Model			
Country of Origin			
Technical Specification and Minimum Requirements	<ul style="list-style-type: none"> ● 3 Ton Auto Strut Coil Spring Compressor & 4 X Snap Joints ● Hydraulic operated with pedal ● Vice height adjustment ● ISO9001 certified ● Material: Steel ● Painted with oil, grease and dirt resistance <ul style="list-style-type: none"> ● Product dimension Length: 5 - 10 inch Width: 9 - 12 inch. Height: 40 - 45 inch. 		
Other Requirements	12 months warranty Company instructional manual		

3. Disc and Drum Brake Service Set



Bidding Document for G-13 Procurement of Automobile Tools and Equipment (Lot 1-8)

Features	Required	Complie d	Bidder's specifications
		(Yes/No)	(Please attach the original brochures)
Make and Model			
Country of Origin			
Technical Specification and Minimum Requirements	<ul style="list-style-type: none"> • Brake Tool Sets w/ 18 Pc Disc Brake Caliper Tool Kit & 8 Pc Drum Brake Tool Kit • Includes a holding plate, right and left-hand thrust bolt, a 3/8" drive adapter, 4 single pin discs, 6 two pin discs, 1 three pin disc, 1 four pin disc, 1 no pin disc, and 1 hex disc; Drum brake tools include break spring installer, brake spring pliers, spring compressor, brake adjustment spoon, 2 spring removers, and 2 brake spring retainers 		
Other Requirements	12 months warranty Company instructional manual		

4. Vacuum Operated Hydraulic Brake Bleeding Kit

Features	Required	Complie d	Bidder's specifications
		(Yes/No)	(Please attach the original brochures)
Make and Model			
Country of Origin			

Bidding Document for G-13 Procurement of Automobile Tools and Equipment (Lot 1-8)

<p>Technical Specification and Minimum Requirements</p>	<ul style="list-style-type: none"> • Fluid is dispensed under pressure down through the master cylinder, while air and old fluid are expelled through the bleed screw(s) • Integrated manual pump adds air above the fluid level to prevent aeration • Internal pump components are sealed against exposure to fluids • Integrated safety and manual pressure relief valve • Includes seven master cylinder adapters (with storage case) • Japan type air jack  		
<p>Other Requirements</p>	<p>12 months warranty Company instructional manual</p>		

5. Wire stripper

Features	Required	Complied	Bidder's specifications (Please attach the original brochures)
		(Yes/No)	
<p>Make and Model</p>			

Country of Origin			
Technical Specification and Minimum Requirements	<ul style="list-style-type: none"> • Wire Stripper with stripping head that adjusts to strip: 10-20 AWG solid, 12-22 AWG stranded, and 12/2 and 14/2 Romex cable (all sizes) and other non-metallic (type NM) sheathed cable • Adjustable stopper to control the length of the core strip • Product dimension Length: 8 - 9 inch Width: 3 - 5 inch. Height: 1 - 2 inch. 		
Other Requirements	12 months warranty Company instructional manual		

6. Bearing Pullers

Features	Required	Complie d	Bidder's specifications
		(Yes/No)	(Please attach the original brochures)
Make and Model			
Country of Origin			
Technical Specification and Minimum Requirements	<ul style="list-style-type: none"> • Bearing Pulling Attachment (Separator) • 1 PC. Puller yoke and center screw • 2 PC. Extension rod x L 170mm 		

Bidding Document for G-13 Procurement of Automobile Tools and Equipment (Lot 1-8)

	<ul style="list-style-type: none"> • Ball ended threaded adapter : • 2 PC. 15.0mm / 2 PC. 17.4mm • 2 PC. 20.0mm / 2 PC. 25.2mm • 2 PC. 30.0mm / 2 PC. 36.4mm • Blow-moulded carry case 		
Other Requirements	12 months warranty Company instructional manual		

7. Internal (Gear) Puller

Features	Required	Complied	Bidder's specifications (Please attach the original brochures)
		(Yes/No)	
Make and Model			

Country of Origin			
Technical Specification and Minimum Requirements	<ul style="list-style-type: none"> ● Internal Puller ● Manual pressure screw type with jaw spread approx 40 ~ 180 mm ● Two-Jaw gear puller ● Adjustable sliding arm for efficiency and safety ● Reversible jaws for internal & external options gear, axle, bearing, etc. ● Size: 3.5", 5", 6", 8", 10" 		
Other Requirements	12 months warranty Company instructional manual		

8. Set, Assortment of Tools (Metric)

Features	Required	Complie d	Bidder's specifications
		(Yes/No)	(Please attach the original brochures)
Make and Model			
Country of Origin			
Technical Specification and Minimum Requirements	Drive Size 1/2 in, 1/4 in * Set Type Socket Set * Drive Type Square * Set Contents Adaptor, Bits, Extension, Ratchet, Sliding T-bar, Sockets, Spanners, Universal Joint * Socket Size 4 mm, 4.5 mm, 5 mm, 5.5 mm, 6 mm, 7 mm, 8 mm, 9 mm, 10 mm, 11 mm, 12 mm, 13 mm, 14 mm, 15 mm, 16 mm, 17		

	<p>mm, 18 mm, 20 mm, 21mm, 22mm, 23 mm, 24 mm, 27 mm, 32 mm, 34 mm</p> <p>* Finish Chrome</p> <p>* Material Chrome Vanadium Steel</p> <p>Phillips Screwdriver: PH2 x 100 mm</p> <p>Pozidriv Screwdriver: PZ1 x 80 mm PZ2 x 100 mm PZ1 x 75 mm</p> <p>Slotted Screwdriver: 0.4 x 2.5 mm 0.6 x 3.5 mm 0.8 x 4.0 mm 1.0 x 5.5 mm 1.2 x 6.5 mm</p> <p>Torx: T10 x 75 mm T15 x 100 mm T20 x 100 mm T25 x 125 mm</p>		
--	--	--	--

			
Other Requirements	12 months warranty		

9. Oil Filter Removal Cup Wrench Set, in a Protective Box

Features	Required	Complied	Bidder's specifications (Please attach the original brochures)
		(Yes/No)	

Make and Model			
Country of Origin			
Technical Specification and Minimum Requirements	<ul style="list-style-type: none"> • Oil Filter Socket Set • 3/8" Oil Filter Socket • Oil filter wrench set profile sockets sizes: 76MM-30P, 75/77MM-15P, 80MM-15P, 66MM-6P, 65/67MM-14P, 76MM-8P, 65MM-14P, 68MM-14P, 80/82MM-15P, 74MM-15P, 76MM-12P, 74/76MM-15P, 73MM-14P, 76MM-14P, 78MM-15P, 100MM-15P, 106MM-15P, 108MM-15P, 108MM-18P, 92MM-10P, 93MM-15P, 86MM-18P, 93MM-36P, 93MM-45P, 90MM-15P, 86MM-16P, 65-120MM, 3-jam wrench, 96mm-18p, 95mm-15p 		
Other Requirements	12 months warranty		

10.7-Drawer Tool Trolley with Lock

Features	Required	Complied	Bidder's specifications
		(Yes/No)	(Please attach the original brochures)
Make and Model			
Country of Origin			
Technical Specification	<ul style="list-style-type: none"> • 7-Drawer Tool Trolley with Lock 		

<p>and Minimum Requirements</p>	<ul style="list-style-type: none"> • Lock & Go latching system prevents drawers from opening when the trolley is being moved • Fully opening drawers with aluminum trims • Scratch Proof powder coating • Double walled case : if the outside wall is damaged in a collision, the double walled case ensures that the drawers will always open • Solid steel construction • Anti-slip rubber worktop • A solid handle that can be fixed in both side of the trolley • Secure round locking system protects the trolley against theft • Noiseless rubber wheels approx 150x50 mm with 2 brakes : 2 fixed and 2 swivel with brake <p>Drawers internal dimensions approx:</p> <ul style="list-style-type: none"> • (2 x) 881 x 445 x 53 mm • (3 x) 881 x 445 x 118 mm • (1 x) 881 x 445 x 184 mm <div data-bbox="461 1102 1015 1690" style="text-align: center;"> <p>The image shows a red Bahco C75 trolley. It has a main body with the 'BAHCO' logo in large black letters at the bottom. The top of the trolley has a black handle. On the left side, there are several drawers with silver-colored metal trims. The trolley is mounted on four black wheels, two of which are swivel casters with brakes. The model number 'C75' is visible on the top right corner of the trolley's frame.</p> </div>		
<p>Other Requirements</p>	<p>12 months warranty ISO 9001 certified</p>		

11. Valve Guide Driver/Removal tool Set

Features	Required	Complie d	Bidder's specifications
		(Yes/No)	(Please attach the original brochures)
Make and Model			
Country of Origin			
Technical Specification and Minimum Requirements	<ul style="list-style-type: none"> Valve Guide Valve Removal Tool Plunger Disc Removal Punching Tool Valve Guide Pilots Remover: 5mm,5.5mm,6mm,6.5mm, 7mm,8mm,9mm,9.5mm, 10mm,10.5mm,11mm Japan type air jack 		
Other Requirements	12 months warranty Operation instructional manual		

12. Valve Guide Reamer Set

Features	Required	Complie d	Bidder's specifications
		(Yes/No)	(Please attach the original brochures)
Make and Model			

Country of Origin			
Technical Specification and Minimum Requirements	<ul style="list-style-type: none"> ● HSS Valve Stem Guide Reamers Spiral Fixed set of 5 pieces ● Squared Head ● Sizes: <ul style="list-style-type: none"> -1/4" inches - 4" inches Long, -9/32" inches - 6" inches Long, -5/16" inches - 6" inches Long, -11/32" inches - 6" inches Long -3/8" inches - 6" inches Long 		
Other Requirements	12 months warranty		

13. Vee Block (P-shaft)

Features	Required	Complie d	Bidder's specifications
		(Yes/No)	(Please attach the original brochures)
Make and Model			
Country of Origin			
Technical Specification and Minimum Requirements	<ul style="list-style-type: none"> ● Magnetic Vee Block ● Hardness:55-60 HRC ● Accuracy: 8 microns ● Block length: 90 to 110 mm ● Block width: 60 to 90 mm ● Material: Stainless steel ● Magnet lock function 		

			
Other Requirements	12 months warranty		

14. Bearing Race & Seal Driver Set

Features	Required	Complied (Yes/No)	Bidder's specifications (Please attach the original brochures)
		Make and Model	
Country of Origin			

<p>Technical Specification and Minimum Requirements</p>	<p>Features: Separates fittings on automotive fluid lines, including AC, fuel, oil and transmission lines</p> <p>Set contents: 9pc adaptors - SIZE;1.565", 1.75", 1.965", 2.31", 2.47", 2.555", 2.83", 2.995", 3.18"</p> 		
<p>Other Requirements</p>	<p>12 months warranty</p>		

15. Swivel joint spanner set

Features	Required	Complie d	Bidder's specifications (Please attach the original brochures)
		(Yes/No)	
<p>Make and Model</p>			
<p>Country of Origin</p>			
<p>Technical Specification and Minimum Requirements</p>	<p>12-Piece Flex-Head Ratcheting Wrench Set, Metric Combination Spanner Kit, Chrome Vanadium Steel Ratchet Wrenches Set with Carrying Case Size: 8mm, 9mm, 10mm, 11mm, 12mm, 13mm, 14mm, 15mm, 16mm, 17mm,18mm, 19mm</p>		

			
Other Requirements	12 months warranty		

16. Portable Battery Power Screwdriver

Features	Required	Complied	Bidder's specifications (Please attach the original brochures)
		(Yes/No)	
Make and Model			
Country of Origin			
Technical Specification and Minimum Requirements	<ul style="list-style-type: none"> ● Cordless Screwdriver, Rechargeable Electric Screwdriver Set (drill bits, driver bits, bits holder, sockets, socket connector, flexible shaft) ● Battery Indicator, ● 7 Torque Setting, ● 2 Position Handle with LED Light, Flexible Shaft ● Head style: Hex ● Torque: 3 to 4 Newton Meters ● Battery cell type: Lithium Ion ● Materials: Acrylonitrile Butadiene Styrene, Rubber 		

			
Other Requirements	12 months warranty		

17. Heat shrink blower

Features	Required	Complied	Bidder's specifications (Please attach the original brochures)
		(Yes/No)	
Make and Model			
Country of Origin			
Technical Specification and Minimum Requirements	<ul style="list-style-type: none"> ● Cordless Heat shrink blower, ● Temperature Max 500 to 550°C ● Product dimension: ● Length: 5 to 7 inch ● Width: 5 to 8 inch ● Height: 5 to 7 inch ● Battery cell type: Lithium Ion, 12 to 24V ● Power source: Battery powered Set Contents: ● Battery, Charger, Heat Nozzles 		

			
Other Requirements	12 months warranty		

18. Blind hole puller kit

Features	Required	Complied	Bidder's specifications (Please attach the original brochures)
		(Yes/No)	
Make and Model			
Country of Origin			
Technical Specification and Minimum Requirements	<ul style="list-style-type: none"> ● 16 Piece Blind Pilot Inner Bearing Pullers – Slide Hammer Puller Set and U-Shaped Wheel Bearing Puller Kit ● Collet Sizes: 8-11mm, 12-17mm, 18-23mm, 24-29mm, 30-34mm, 34-38mm, 39-43mm, 44-48mm, 49-53mm, and 54-58mm ● Screw Adaptor Sizes: M10x1.5p, M10x1.5p/M8x1.25p, M10x1.5p/M6x1.0p 		

Bidding Document for G-13 Procurement of Automobile Tools and Equipment (Lot 1-8)

Other Requirements	12 months warranty		

Lot 5-Automobile Equipment (LD)

1. Part Washer

Features	Required	Complied	Bidder's specifications
		(Yes/No)	(Please attach the original brochures)
Make and Model			
Country of Origin			
Technical Specifications and Minimum Requirements	<p>This equipment to be used for automobile car parts cleaning/washing in automobile workshops.</p> <p>Bucket / Basin dimension Length: 20 - 30 inch Width: 25 - 30 inch. Height: 15 - 20 inch. Has restoration flow system while functioning. Storage capacity 55 - 65 L. Working pressure 1 - 3 bar. Has a rotary pump. Output Watts: 1,000-1200 W Heater Type: Immersion With Filtration: Yes Has wheels for transport. Made from stainless steel. Painted with oil, grease and dirt resistance</p>		

			
Other Requirements	Operation manual 12 months warranty Training on operation		

2. Headlight Aimer

Features	Required	Complied	Bidder's specifications
		(Yes/No)	(Please attach the original brochures)
Make and Model			
Country of Origin			

Technical Specification and Minimum Requirements	<p>Measuring Range</p> <ol style="list-style-type: none"> 1. Central Height of Headlight : 50cm ~ 130cm 2. Light Intensity: 0 ~ 60,000cd (standard) 3. 0 ~ 120,000cd (maximum) <p>Resolution</p> <ol style="list-style-type: none"> 1. Light Intensity of High Beam: ± 100cd <p>Indication Error</p> <ol style="list-style-type: none"> 1. Light Intensity of High Beam: $\pm 12\%$ <p>Measuring Distance : 30 ~ 50cm</p> <p>Dimension: 500 to 600 mm(W) 1750 1850 mm(H) 500 to 600 mm(D)</p> <p>Operation Condition</p> <ol style="list-style-type: none"> 1. Environmental Temperature : 5 ~ 40°C 2. Relative Humidity: Less than 95% 3. Atmosphere Pressure : 70.0 ~ 106.0KPa 		
---	--	--	--

			
Other Requirements	<ul style="list-style-type: none"> • Instruction/operation manual • 12 months warranty 		

3. 5-Gas Vehicle Emissions Analyzer

Features	Required	Complied	Bidder's specifications
		(Yes/No)	(Please attach the original brochures)
Make and Model			
Country of Origin			

**Technical
Specification
and
Minimum
Requirements**

QVGA Display and easy to read all gases and Lambda on one screen

- Bluetooth and USB Cable ready Links analyzer easily to PC to use with LIVE Graphing Software
- Optional Hi-Speed Print Capability

Use with the hi-speed printer with rechargeable battery

- Probe

Equipped with the Hi-Temperature Probe, with tubing.
Clip handle to secure to exhaust, 4m long hose

- Tests HC, O2, CO, CO2, NOX and Lambda
- Self-calibrating

Accessory:

- 20 rolls of printer paper
- 10 sets of replacement filters



Other Requirements	<ul style="list-style-type: none"> · Instruction manual · 12 months warranty · Supplier must provide the equipment usage training 		
---------------------------	--	--	--

4. Diesel Smoke Meter

Features	Required	Complied	Bidder's specifications
		(Yes/No)	(Please attach the original brochures)
Make and Model			
Country of Origin			

Technical Specification and Minimum Requirements	<p>Measuring items: Smoke opacity (%, k [m-1]) RPM (optional), Oil temperature (optional) Detector: Photodiode Length/Diameter (cell): Length: 215 mm(± 0.5 mm) / Diameter 21 mm Measuring range: 0.0 – 99.9% (K: 0 – 9.99 m) Accuracy: 0.10% Response time: $<0.5 \pm 0.015$ sec. Power: AC 110V/220V, 50/60Hz Operation temperature: - 10 to 40°C</p> <p>Product Dimension: Length: 300 - 400 mm Width: 250 - 300 mm Height: 250 - 350 mm ISO9001 certified</p> 		
Other Requirements	<ul style="list-style-type: none"> · Company instruction manual · 12 months warranty · Machine supplier will provide training 		

5. Recycling/Recharging Refrigerant Machine

Features	Required	Complied	Bidder's specifications
		(Yes/No)	(Please attach the original brochures)
Make and Model			
Country of Origin			

<p>Technical Specification and Minimum Requirements</p>	<p>Power sources: -Input Voltage: AC220 - 230V Frequency 50Hz with B3 type, B3L type power plug or three-phase AC415V. Unit includes a 3.0 CFM (84 L/m) high-vacuum pump for fast, thorough evacuation graphical LCD Display: Length 8 to 9 cm Width: 3 to 4 cm Humidity: 10–50°C (50–122°F), 86% RH non-condensing Maximum Pressure: 30- 32 bar (450 PSI) Vacuum Pump Free-Air Displacement: 3 to 4 CFM (84 L/m) Vacuum Pump Free-Air Displacement: 3 to 4 CFM (84 L/m) Filtering capacity: 140-150 kg (330 lb) Manometer: Ø 100 mm (3.9 in.) Oil Bottle Capacity: 300 to 400 ml Service Hoses: HP and LP hoses</p> 		
<p>Other Requirements</p>	<ul style="list-style-type: none"> · Company instruction manual · 12 months warranty <ul style="list-style-type: none"> ● Machine supplier should provide training 		

6. Electronic Ignition Analyzer

Features	Required	Complied	Bidder's specifications
		(Yes/No)	(Please attach the original brochures)
Make and Model			
Country of Origin			

<p>Technical Specification and Minimum Requirements</p>	<ul style="list-style-type: none"> · Screen size : L 50 to 55mmxW 65 to 75 mm · Measurable ignition Systems: Direct ignition, High-tension code, Wasted spark ignition systems · Engine Types: 2 and 4 stroke engine cycle · Power Supply: Rechargeable lithium battery · Product Dimensions Length: 25 - 35 mm Width: 80 - 120 mm Height: 150 - 200 mm Accessories: <ul style="list-style-type: none"> ● Flexible Probe ● USB Cable ● Direct Ignition Sensor ● Carrying Case ● High Tension Code Sensor <div style="text-align: center;">  </div>		
<p>Other Requirements</p>	<ul style="list-style-type: none"> · Instruction manual · 12 months warranty · Supplier must provide operation training of equipment 		

7. Hand Operated Vacuum Pump

Features	Required	Complied	Bidder's specifications
		(Yes/No)	(Please attach the original brochures)
Make and Model			
Country of Origin			
Technical Specification and Minimum Requirements	<p>Vacuum Hand Pump - For measuring vacuum range 0 ~ 760 mmHg complete with accessories in a storage case Pressure Range: 0-30inHg, 0-760mmHg Package Included: 1pc Vacuum Pump/Brake Bleeder with Vacuum Gauge 1pc Reservoir Jar & 2 x Lids 1pc "T" Hose Connector 1pc Straight Hose Connector 1pc Universal Cup Adapter 2pcs 24" Vacuum Hoses 2pcs 3" Vacuum Hoses 2pcs Tapered Hose Adapters 3pcs Brake Bleeder Valve Adapters 1pc Blow Molded Carry Case</p> 		
Other Requirements	<ul style="list-style-type: none"> · Instruction manual · 12 months warranty 		

8. Scissors Hoist

Features	Required	Compl ied	Bidder's specifications
		(Yes/N o)	(Please attach the original brochures)
Make and Model			
Country of Origin			

<p>Technical Specification and Minimum Requirements</p>	<p>Power sources: -Input Voltage: AC220 - 230V Frequency 50Hz with B3 type, B3L type power plug or three-phase AC415V.</p> <ul style="list-style-type: none"> ● Min. Lifting Height: 1000mm or more ● Lifting Capacity: 3 Ton or more ● Lifting Time: 35 Seconds or less ● Motor: 2.8 to 3.2hp <p style="text-align: center;">Product dimension</p> <ul style="list-style-type: none"> ● Overall Length (inc ramp):1950 to 2050mm ● Overall Length (excl ramp): 1400 to 1500mm ● Overall Width (excl toe-protectors):1700 to 1800mm ● Overall Width (Incl toe protectors): 2000 to 2100mm ● Runway Width 500 to 550mm ● First Lock Height: 500 to 600mm ● Hand pump - also lowering if power failure ● Broken hose protection <p>Main Features:</p> <ul style="list-style-type: none"> ● Variable locking positions ● Height Limit Switch ● Electric and Hydraulic Power System ● Built in motor overload protection device ● 4 rubber attachments 		
<p>Other Requirements</p>	<ul style="list-style-type: none"> · Instructional manual · 12 months warranty · After installation of the equipment, the supplier should check that the product is working. 		

9. 2 Posts Electro-Hydraulic Hoist

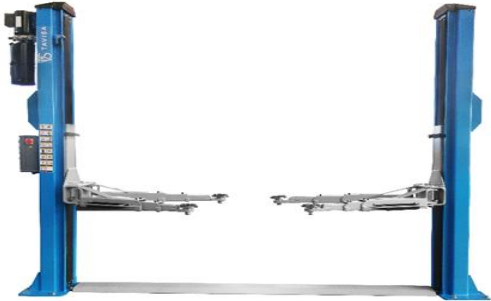
Features	Required	Complied	Bidder's specifications
		(Yes/No)	(Please attach the original brochures)
Make and Model			
Country of Origin			
Technical Specification and Minimum Requirements	<p>Power sources: -Input Voltage: AC220 - 230V Frequency 50Hz with B3 type, B3L type power plug or three-phase AC415V.</p> <ul style="list-style-type: none"> • Lifting Capacity: 3000kg to 5 000 kg • Maximum Lifting Height: 1800 to 2000 mm • Minimum Lifting Height: 100 to 150 mm • Overall Height: 2800 to 2900 mm • Overall Width: 3600 to 3700 mm • Width Between Columns: 2750 to 2850 mm • Maximum Vehicle Width: 2400 to 2600 mm <p>Full-flat floor (No wire connections or objects such as wire covers on the floor.)</p> 		

Bidding Document for G-13 Procurement of Automobile Tools and Equipment (Lot 1-8)

Other Requirements	<ul style="list-style-type: none"> · Instructional manual · 12 months warranty · After installation of the equipment, the supplier should check that the product is working. 		
---------------------------	---	--	--

10. Compressed Air Hose Reels - ceiling hung

Features	Required	Complied	Bidder's specifications
		(Yes/No)	(Please attach the original brochures)
Make and Model			
Country of Origin			
Technical Specification and Minimum Requirements	<ul style="list-style-type: none"> · Drive mechanism: self-retracting (Spring rewind automatically) · Configuration: side-mount / ceiling mount · Application: Compressed air · Hose length: at least 16 to 20 m · Hose material: Polyurethane · Max. working pressure: 8 to 10 bar 		

			
Other Requirements	<ul style="list-style-type: none"> · Instructional manual · 12 months warranty 		

11. Exhaust Extraction Hose Reels

Features	Required	Complied	Bidder's specifications
		(Yes/No)	(Please attach the original brochures)
Make and Model			
Country of Origin			

<p>Technical Specifications and Minimum Requirements</p>	<p>Exhaust Extraction Hose Reels - Wall mounted or ceiling hung - Includes ducting to external of building Reel: * Drive: Electric motor * Frequency: (Hz)50/60 * Diameter, hose: Min 100mm * Hose length: 10m or more Nozzle: * Hose connection Diameter (mm) 90 to 110 * Max exhaust pipe, diameter. Dual (mm)100 x 75 * Max exhaust pipe, single: 75 mm * Vehicle type: Passenger car</p> 		
<p>Other Requirements</p>	<ul style="list-style-type: none"> • With user manuals and full accessories • 12 months warranty 		

12. Hydraulic Jack-Lifting capacity up to 2000 kg

Features	Required	Complied	Bidder's specifications
		(Yes/No)	(Please attach the original brochures)
Make and Model			
Country of Origin			
Technical Specification and Minimum Requirements	<p>Lifting capacity: 2000 kg to 2500kg Min. height: 140 to 150 mm Max. height: 700 to 850 mm Saddle diameter: 120 to 130 mm Total length without pumping rod: 1100 to 1200 mm Width at the front castors: 290 mm Width at the rear castors: 430 mm Cast steel castors: 2 fixed front castors + 2 swivel rear castors Jack Mechanism: Hydraulic Painted with oil, grease and dirt resistant ISO certification: 9001 <i>T-grip pumping rod: valve operating mechanism inside.</i> <i>Knob for opening or closing the valve is located on the top of the pumping rod.</i></p> 		

Other Requirements	12 months warranty		
---------------------------	--------------------	--	--

13. Safety Stand

Features	Required	Complied	Bidder's specifications
		(Yes/No)	(Please attach the original brochures)
Make and Model			
Country of Origin			

**Technical
Specification
and
Minimum
Requirements**

- Capacity: Min. 3 ton
- Min.Height (mm): 285
- Max.H.(mm): 428
- Materials: Heavy duty cast iron support post
- Oversized saddles provide positive contact and added stability
- Dual purpose handle for saddle column lock release and portable transport
- All welded steel frame construction with cast iron support arms with rust resistant finish for longer tool life.
- Self-locking ratchet provided for adjustment
- Painted with oil, grease and dirt resistant
- ISO certification: 9001



Other Requirements	12 months warranty		
---------------------------	--------------------	--	--

14. Waste Fluid / Oil Collection Tank

Features	Required	Complied	Bidder's specifications
		(Yes/No)	(Please attach the original brochures)
Make and Model			
Country of Origin			

<p>Technical Specification and Minimum Requirements</p>	<ul style="list-style-type: none"> · Oil Tray (Basin) Capacity: 10 to 15L · Tank Capacity: 70 to 80L · Material: Steel · Adjustable Height: 100-160cm · Waste tank supported with castor wheels · Length of drain hose: 1 to 1.75m · Equipped with pressure regulating valve · Painted with oil, grease and dirt resistant Installed with Stainless steel handle 		
<p>Other Requirements</p>	<p>12 months warranty</p>		

15. Forklift

Features	Required	Compl ied	Bidder's specifications
		(Yes/No)	(Please attach the original brochures)
Make and Model			
Country of Origin			
Technical Specification and Minimum Requirements	<p>Capacity: 5 Ton or more Power Source: Diesel Engine Rated Loading Capacity: 5000kg Max. Lifting Height: 4300 to 4500mm Min. Lifting Height: 2500 to 2600mm Fork Length: 1200 to 1300mm Fork Width: 140 to 160mm Product Dimension: Length: 3400 to 3600 mm Width: 1900 to 2100 mm Height: 2300 to 2500 mm Certification: ISO, CE, EPA Load Centre: 600mm Wheelbase: 2200 to 2250 mm Fuel Tank Capacity: 110 to 130L</p> 		

Other Requirements	24 months warranty Service Manual and Operation manual		
---------------------------	---	--	--

16. Pallet jack

Features	Required	Complied	Bidder's specifications
		(Yes/No)	(Please attach the original brochures)
Make and Model			
Country of Origin			
Technical Specification and Minimum Requirements	<ul style="list-style-type: none"> • Capacity: 3 to 4 ton • Wheels/Rollers: Polyurethane/Steel • Lift Height: min 6.5 inch • Lowered Height: min 2" • Fork Length(s): 45" to 48" • Overall Fork Width: 21" to 27" • Fork Width: 6.5" • 200 degree handle pivot 		

Other Requirements	12 months warranty Service Manual and Operation manual		
---------------------------	---	--	--

17. Portable Surface Table

Features	Required	Complied	Bidder's specifications
		(Yes/No)	(Please attach the original brochures)
Make and Model			
Country of Origin			
Technical Specification and Minimum Requirements	<p>Surface Finish: Grade 0 Granite Thickness: 60 to 80mm Granite Length: 1800 to 2000mm Granite width: 800 to 1000mm Table height: 800 to 1000mm Material: Granite Stand: Steel stand Painted with oil, grease and dirt resistance</p> 		

Other Requirements	12 months warranty		
---------------------------	--------------------	--	--

18. Air compressor

Features	Required	Complied	Bidder's specifications
		(Yes/No)	(Please attach the original brochures)
Make and Model			
Country of Origin			

**Technical
Specification
and
Minimum
Requirements**

Motor power: 4 to 5 Kw
Power supply: 3 phase
Rotation speed: 2800 to 3000 rpm
Pressure: 10 to 12.5 bar
Free air delivery: 20 to 25m³/h
Tank capacity: 300 to 350L
Compressor technology: Screw type
ISO 9001 ISO 14001 quality assurance

Safety

- Emergency stop
- General alarm
- Fault shut down & alarm function
- Reverse rotation protection
- Maintenance alarm
- Motor overload protection



Other Requirements	12 months warranty Service Manual and Operation manual		
---------------------------	---	--	--

19. Power Compression Crimping Tools

Features	Required	Complied	Bidder's specifications
		(Yes/No)	(Please attach the original brochures)
Make and Model			
Country of Origin			
Technical Specification and Minimum Requirements	Range of Application: 4-70 MM ² Standard Dies: 4/6/10/16/25/35/50/70 MM Application: for press CU/AL cable lugs Crimping Force: 5 to 6 Ton Stroke:12 MM or more Crimping Type: Hexagon Crimping		

			
<p>Other Requirements</p>	<p>12 months warranty Service Manual and Operation manual</p>		

20. Automatic Transmission Diagnostic Set

Features	Required	Complied	Bidder's specifications
		(Yes/No)	(Please attach the original brochures)
<p>Make and Model</p>			
<p>Country of Origin</p>			

Technical Specifications and Minimum Requirements	<p>Set contains two gauge assemblies for high and low pressure ranges.</p> <p>11 Adaptors to test a wide variety of automatic transmissions.</p> <p>Special fittings included for connection to hard-to-reach test ports in areas requiring a 45° or 90° angle.</p> <p>Low pressure gauge: 0-7bar(0-100psi).</p> <p>High pressure gauge: 0-35bar(0-500psi).</p> <p>Hose length:500mm to 1000mm</p> 		
Other Requirements	<p>12 months warranty Service Manual and Operation manual</p>		

Lot 6-Automobile Simulator (KP)

1. Air Bag Simulator

Features	Required	Complied	Bidder's specifications
		(Yes/No)	(Please attach the original brochures)
Make and Model			
Country of Origin	-		
Technical Specification and Minimum Requirements	<ul style="list-style-type: none"> • Consist of driver/passenger seat airbags, airbag modules, seat belts, PPD sensor, air regulators and 2 air tanks (approx: 10-15L) • Size 		

	<p>Length: 900 to 1100 mm Width: 1900 to 2100 mm Height: 1100 to 1300 mm</p> <ul style="list-style-type: none"> • The simulator is supported by metal frames and 4 wheels for mobility 		
			
Other Requirements	24 months warranty Operation manual		

2. Analog and Digital Trainer Kit

Features	Required	Complied	Bidder's specifications
		(Yes/No)	(Please attach the original brochures)
Make and Model			
Country of Origin			
Technical Specification and Minimum Requirements	<ul style="list-style-type: none"> • Power source available: 110V/220V; • 3 digit 7 segment display (0~9 and A~F) available; • Length: 1.5-2 metres • Bread: 1-1.5 metres • Breadboard available to practise & design various electronic circuit of both analog and digital fields • TR check function available • Practice and design of various transistor circuits and OP amp circuits are available • Decoder embedded in the kit 		

			
Other Requirements	24 months warranty Operation manual		

3. Electricity Master

Features	Required	Complied	Bidder's specifications
		(Yes/No)	(Please attach the original brochures)
Make and Model			
Country of Origin			
Technical Specification and Minimum Requirements	<ul style="list-style-type: none"> ● Composition: Automotive Electrical Circuit Training System-Block Type ● Size: Length: 250 to 350 mm Width: 150 to 250 mm Height: 100 to 200 mm ● Electric devices of each part of the Power Window System installed on the aluminium panel for tests; ● Connection terminals installed at each sensor, circuit and component so that wiring practices can be conducted and wave patterns can be measured. 		

			
Other Requirements	24 months warranty Operation manual		

4. Spark Ignition Engine Management System Model

Features	Required	Complied	Bidder's specifications (Please attach the original brochures)
		(Yes/No)	
Make and Model			
Country of Origin			
Technical Specification and Minimum Requirements	<ul style="list-style-type: none"> ● Power supply: 220V ● Dimensions ● Height:1800 to 1900 mm ● Length: 1300 to 1500 mm ● Width:500 to 700 mm ● Training board is based on OEM components. ● Integrated engine control system with direct petrol injection available. ● Training board has a complete electric wiring diagram of the direct petrol injection system. ● Electric wiring diagram with built – in banana plug jumpers for measurements and simulation of system fault codes. ● Training board has an integrated voltmeter. ● The stand has a closed structure – internal wiring is not visible. ● Integrated simulators available that allow to change parameters of each system component: 		

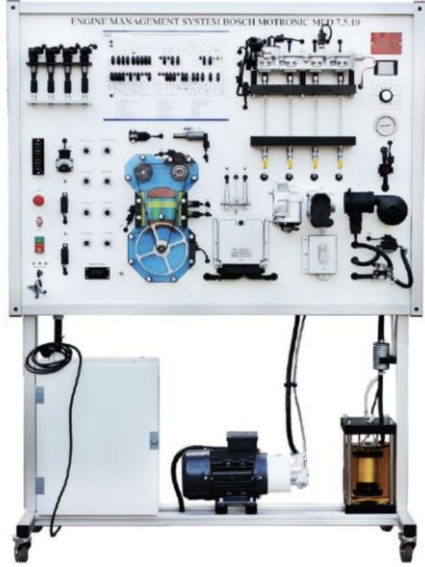
	<ul style="list-style-type: none"> - Lambda probe signal simulation - Engine operation temperature simulation - NOx sensor parameter simulation - Exhaust gas temperature sensor simulation - Intake manifold pressure sensor simulation 		
Other Requirements	24 months warranty Operation manual		

5. Common Rail Fuel System simulator

Features	Required	Complied	Bidder's specifications
		(Yes/No)	(Please attach the original brochures)
Make and Model			
Country of Origin			
Technical Specification and Minimum Requirements	<p>Power sources:</p> <ul style="list-style-type: none"> -Input Voltage: AC220 - 230V Frequency 50Hz with B3 type, B3L type power plug or three-phase AC415V. <ul style="list-style-type: none"> ● Dimension: <ul style="list-style-type: none"> Length: 900 to 1100 mm Width: 900 to 1100 mm 		

	<p>Height: 1400 to 1600 mm</p> <ul style="list-style-type: none"> ● Three-phase motor is installed; Equipped with a variable-frequency governor ● A digital gauge is installed on the board to display real-time changes of engine sensor parameters ● The board has a circuit diagram, installed with a detection terminal (to detect the electrical signal of the sensors, actuators, automatic air conditioning control unit pin on the board, such as resistance, voltage, current, frequency signals) ● The diesel common rail system has self-diagnosis functions such as reading fault codes, clearing fault codes and reading data streams <p>Teaching board:</p> <ul style="list-style-type: none"> ● Mobile casters ● Working temperature approx: -20°~+40°. ● Movable stand (with section view principle teaching board). ● The equipment frame is constructed of 40mm×40mm integrated all-aluminum alloy profiles ● The table is approx 40CM wide, and is paved with 32mm-thick colour high-density composite board ● It has 4 self-locking devices. ● Swivel casters for easy movement. ● It is equipped with a fault setting system and a diagnosis socket, which is connected to a special or general purpose automobile decoder. 		
--	--	--	--

			
Other Requirements	24 months warranty Operation manual		

6. 4-stroke SI Engine Cut-away model

Features	Required	Complied	Bidder's specifications
		(Yes/No)	(Please attach the original brochures)
Make and Model			
Country of Origin			
Technical Specification and Minimum Requirements	<p>Features: Single cylinder Internal engine components visible with</p> <ul style="list-style-type: none"> - piston and connecting rod - Valves and cam actuation - crankshaft - timing gears - spark plug <p>To be used for teaching the four stroke engine principle operation</p> <ul style="list-style-type: none"> - Crankshaft driven by hand drive wheel 		

	<p>- Engine Mounted on base with engine diagram labelling</p> <p>Item size: Length: 20 - 50cm Height: 30 - 70cm Depth: 20 - 50cm</p> 		
<p>Other Requirements</p>	<p>24 months warranty Operation manual</p>		

7. 4-stroke Diesel Engine Cut-away model

Features	Required	Complie d	Bidder's specifications
		(Yes/No)	(Please attach the original brochures)
Make and Model			
Country of Origin			

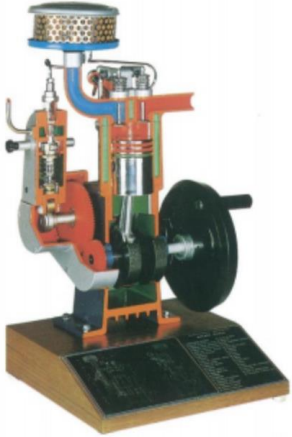
<p>Technical Specification and Minimum Requirements</p>	<p>Features:</p> <ul style="list-style-type: none"> -Educational cutaway model of an automobile four-stroke diesel engine. -Rotating the handlebar turns the crank and reproduces the up-and-down movement of the piston, valve opening. -Single Cylinder type <p>Item size:</p> <p>Length: 20 - 50cm Height: 30 - 70cm Depth: 20 - 50cm</p> 		
<p>Other Requirements</p>	<p>24 months warranty Operation manual</p>		

8. Two-Stroke Engine Cut-away model

Features	Required	Complied	Bidder's specifications
		(Yes/No)	(Please attach the original brochures)
<p>Make and Model</p>			
<p>Country of Origin</p>			
<p>Technical Specification and Minimum Requirements</p>	<p>Features:</p> <ul style="list-style-type: none"> -Educational cutaway model of a car or two-wheeled two-stroke engine. 		

Bidding Document for G-13 Procurement of Automobile Tools and Equipment (Lot 1-8)

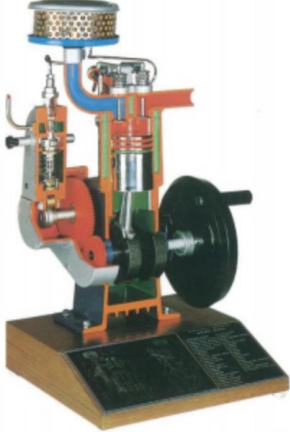
	<p>-Rotating the handlebar turns the crank and reproduces the up-and-down movement of the piston. -Single Cylinder type</p> <p>Item size: Length: 20 - 50cm Height: 30 - 70cm Depth: 20 - 50cm</p> 		
Other Requirements	24 months warranty Operation manual		

9. Final Drive and Differential Cut-away model

Features	Required	Complied	Bidder's specifications
		(Yes/No)	(Please attach the original brochures)
Make and Model			
Country of Origin			
Technical Specification and Minimum Requirements	<p>Features:</p> <ul style="list-style-type: none"> -Educational cutaway model of a differential gear on a rear rigid axle of an automobile. -Rotating companion flanges and tyres can be rotated to simulate the rotational differential of two tyres. -The mechanism of the differential gear and the names of the parts are shown on the pedestal. 		

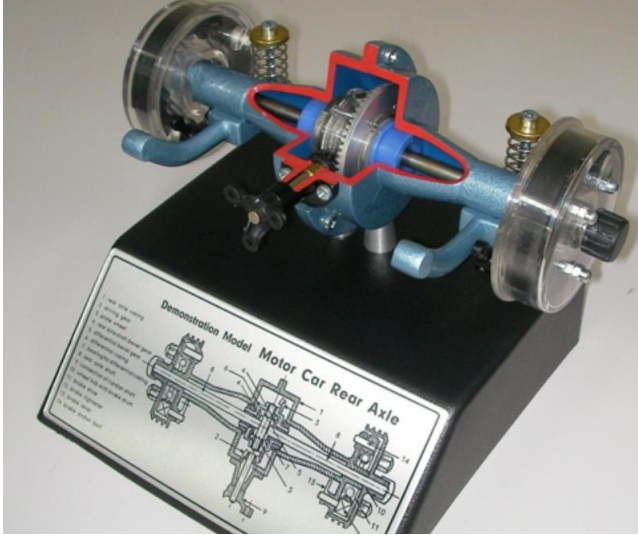
	<p>Item size: Length: 26 - 30 cm Height: 16 - 20 cm Depth: 19 - 23 cm</p> 		
<p>Other Requirements</p>	<p>24 months warranty Operation manual</p>		

Lot 7-Automobile Parts

1. Light Vehicle Automatic Transmission Assembly (Front Wheel Drive)

Features	Required	Compl ied	Bidder's specification s
		(Yes/N o)	(Please attach the original brochures)
<p>Make and Model</p>			

Country of Origin			
Technical Specification and Minimum Requirements	<p>Features:</p> <ul style="list-style-type: none"> - The Transmission is hydraulic operated and has planetary gears. - For use with Petrol engines from 800CC to 2000CC (Front engine front drive) - 4speeds or more gearshifts. - Set with torque converter. 		

2. Light Vehicle All-Wheel Drive Transmission

Features	Required	Complied	Bidder's specifications
		(Yes/No)	(Please attach the original brochures)
Make and Model			
Country of Origin			

<p>Technical Specification and Minimum Requirements</p>	<p>Features:</p> <ul style="list-style-type: none"> - The transmission is hydraulic operated Automatic or manual transmission. - For use with Petrol or Diesel engines from 800CC to 3000CC (All wheel drive) - 4speeds or more gearshifts. 		
---	---	--	--

3. Automatic Transmission (Rear-wheel drive)

Features	Required	Compl ied	Bidder's specification s
		(Yes/N o)	(Please attach the original brochures)
Make and Model			
Country of Origin			

<p>Technical Specification and Minimum Requirements</p>	<p>Features:</p> <ul style="list-style-type: none"> - The Transmission is hydraulic operated and has planetary gears. - For use with Petrol or Diesel engines from 800CC to 3000CC (Rear wheel drive) - 4 speeds or more gearshifts. - Set with a torque converter. 		
---	--	--	--

4. Super charger

Features	Required	Compl ied	Bidder's specification s
		(Yes/N o)	(Please attach the original brochures)
Make and Model			
Country of Origin			

<p>Technical Specification and Minimum Requirements</p>	<p>Features: -Roots blower type - For use with Petrol or Diesel engines from 600CC to 1600CC - Transmission or driven by engine drive belt.</p> 		
---	---	--	--

Lot 8 Furniture

4. Steel Cabinet (Full Height)

Features	Required	Compl ied	Bidder's specification s
		(Yes/N o)	(Please attach the original brochures)
Make and Model			
Country of Origin			

<p>Technical Specification and Minimum Requirements</p>	<p>Steel Cabinet, Full Height - Lockable doors with glass panels Length: 1026mm to 2052mm Wide: 450mm to 600mm Height: 1900 to 2100 mm Fitting: 4 / 5 / 6 / 8 /10/12 Adjustable shelves 1 Central partition 4 / 6 Drawer Made of steel. - Includes installation and commissioning.</p> 		
<p>Warranty</p>	<p>2-year comprehensive on-site warranty</p>		

2. Students' Lab benches

Features	Required	Complied	Bidder's specifications
		(Yes/No)	(Please attach the

			original brochures)
Make and Model			
Country of Origin			
Technical Specification and Minimum Requirements	<p>Dimension: Length: 1500 to 2000 mm Width: 700 to 800mm Height: 800 to 850mm</p> <p>Worktop- 20T+5T Modular worktop (Truss structured aluminum profile+Frosted tempered safely glass/PP/solid phenolic laminate) Frame-Aluminum profile (Anodizing surface coating) Skirt- EGI steel (acid resistant epoxy powder coating) and chemical resistant PP composite. Foot base- PP Power socket × 2 (B3 type or B3L type) Option- Drawer, cabinet, etc</p> 		
Warranty	2-year comprehensive on-site warranty		

3. Storage Rack

Features	Required	Complied	Bidder's specifications
		(Yes/No)	(Please attach the original brochures)
Make and Model			
Country of Origin			
Technical Specification and Minimum Requirements	<p>Dimensions: Height (mm): 1,200 - 3,600 Depth (mm): 450 - 1,200 Length (mm): 900 - 2,450 Shelves per Level: 4 / 5 / 6 Decking Material: 12mm HDF Board / 12mm Plywood Loading Capacity: 600kg - 1,000kg / UDL per level - Includes installation and commissioning.</p> 		
Warranty	2-year comprehensive on-site warranty		

2. Drawings

Section 7: General Conditions of Contract Table of Clauses

1.	Definitions	7-191
2.	Contract Documents	7-3
3.	Fraud and Corruption.....	7-3
4.	Interpretation.....	7-194
5.	Language.....	7-195
6.	Joint Venture.....	7-7
7.	Eligibility	7-7
8.	Notices	7-196
9.	Governing Law.....	7-196
10.	Settlement of Disputes.....	7-196
11.	Scope of Supply.....	7-7
12.	Delivery	7-8
13.	Supplier's Responsibilities	7-8
14.	Purchaser's Responsibilities.....	7-8
15.	Contract Price	7-197
16.	Terms of Payment	7-8
17.	Taxes and Duties.....	7-8
18.	Performance Security	7-9
19.	Copyright	7-9
20.	Confidential Information.....	7-9
21.	Subcontracting.....	7-10
22.	Specifications and Standards	7-10
23.	Packing and Documents.....	7-11
24.	Insurance	7-11
25.	Transportation.....	7-11
26.	Inspections and Tests.....	7-11
27.	Liquidated Damages.....	7-12
28.	Warranty	7-12
29.	Patent Indemnity.....	7-13
30.	Limitation of Liability	7-14
31.	Change in Laws and Regulations.....	7-14
32.	Force Majeure.....	7-14
33.	Change Orders and Contract Amendments	7-15
34.	Extensions of Time	7-15
35.	Termination.....	7-16
36.	Assignment	7-17
37.	Respectful Work Environment	7-17

1. Definitions

46.2 The following words and expressions shall have the meanings hereby assigned to them:

- (a) "Contract" means the Agreement entered into between the Purchaser and the Supplier, together with the Contract Documents referred to therein, including all attachments, appendixes, and all documents incorporated by reference therein.
- (b) "Contract Documents" means the documents listed in the Agreement, including any amendments thereto.
- (c) "Contract Price" means the price payable to the Supplier as specified in the Agreement, subject to such additions and adjustments thereto or deductions therefrom, as may be made pursuant to the Contract.
- (d) "Day" means calendar day.
- (e) "Delivery" means the transfer of the Goods from the Supplier to the Purchaser in accordance with the terms and conditions set forth in the Contract.
- (f) "Completion" means the fulfillment of the Related Services by the Supplier in accordance with the terms and conditions set forth in the Contract.
- (g) "Eligible Countries" means the countries and territories eligible as listed in Section 5.
- (h) "GCC" means the General Conditions of Contract.
- (i) "Goods" means all of the commodities, raw material, machinery and equipment, and/or other materials that the Supplier is required to supply to the Purchaser under the Contract.
- (j) "Purchaser's Country" is the country specified in the Special Conditions of Contract (SCC).
- (k) "Purchaser" means the entity purchasing the Goods and Related Services, as specified in the SCC.
- (l) "Related Services" means the services incidental to the supply of the goods, such as insurance, installation, training and initial maintenance and other similar obligations of the Supplier under the Contract.
- (m) "SCC" means the Special Conditions of Contract.
- (n) "Subcontractor" means any natural person, private or government entity, or a combination of the above, including its legal successors or permitted assigns, to whom any part of the Goods to be supplied or execution of any part of the Related Services is subcontracted by the Supplier.
- (o) "Supplier" means the natural person, private or government entity, or a combination of the above, whose bid to perform the Contract has been accepted by the Purchaser and is named as such in the

Agreement, and includes the legal successors or permitted assigns of the Supplier.

(p) "ADB" is the Asian Development Bank.

(q) "The Site," where applicable, means the place named in the SCC.

2. Contract Documents

2.1 Subject to the order of precedence set forth in the Agreement, all documents forming the Contract (and all parts thereof) are intended to be correlative, complementary, and mutually explanatory.

3. Fraud and Corruption

3.1 If the Purchaser determines, based on reasonable evidence, that the Supplier has engaged in corrupt, fraudulent, collusive or coercive practices, or other integrity violations, including the failure to disclose any required information which constitutes a fraudulent practice, in competing for or in executing the Contract, then the Purchaser may, after giving 14 days' notice to the Supplier, terminate the Contract and expel him from the Site, and the provisions of Clause 35 shall apply as if such termination had been made under Sub-Clause 35.1(a) (iii) [Termination].

3.2 ADB requires Borrowers (including beneficiaries of ADB-financed activity) and their personnel, as well as firms and individuals participating in an ADB-financed activity, including but not limited to, Bidders, Suppliers, and Contractors, agents, subcontractors, subconsultants, service providers, subsuppliers, manufacturers (including their respective officers, directors, employees and personnel) under ADB-financed contracts to observe the highest standard of ethics during the procurement and execution of such contracts in accordance with ADB's Anticorruption Policy (1998, as amended from time to time). In pursuance of this policy, ADB

(a) defines, for the purposes of this provision, the terms set forth below as follows:

(viii) "corrupt practice" means the offering, giving, receiving, or soliciting, directly or indirectly, anything of value to influence improperly the actions of another party;

(ix) "fraudulent practice" means any act or omission, including a misrepresentation, that knowingly or recklessly misleads, or attempts to mislead, a party to obtain a financial or other benefit or to avoid an obligation;

(x) "coercive practice" means impairing or harming, or threatening to impair or harm, directly or indirectly, any party or the property of the party to influence improperly the actions of a party;

(xi) "collusive practice" means an arrangement between two or more parties designed to achieve an improper purpose, including influencing improperly the actions of another party;

(xii) "abuse" means theft, waste, or improper use of assets related to ADB-related activity, either committed intentionally or through reckless disregard;

- (xiii) "conflict of interest" means any situation in which a party has interests that could improperly influence that party's performance of official duties or responsibilities, contractual obligations, or compliance with applicable laws and regulations; and
 - (xiv) "integrity violation" is any act, as defined under ADB's Integrity Principles and Guidelines (2015, as amended from time to time), which violates ADB's Anticorruption Policy, including (i) to (vi) above and the following: obstructive practice, violations of ADB sanctions, retaliation against whistleblowers or witnesses, and other violations of ADB's Anticorruption Policy, including failure to adhere to the highest ethical standard.
- (b) will reject a proposal for award if it determines that the Bidder recommended for award or any of its officers, directors, employees, personnel, subconsultants, subcontractors, service providers, suppliers or manufacturers has, directly or through an agent, engaged in corrupt, fraudulent, collusive, coercive, or obstructive practices or other integrity violations in competing for the Contract;
 - (c) will cancel the portion of the financing allocated to a contract if it determines at any time that representatives of the Borrower or of a beneficiary of ADB-financing engaged in corrupt, fraudulent, collusive, coercive, or obstructive practices or other integrity violations during the procurement or the execution of that contract, without the Borrower having taken timely and appropriate action satisfactory to ADB to remedy the situation, including by failing to inform ADB in a timely manner at the time they knew of the integrity violations;
 - (d) will impose remedial actions on a firm or an individual, at any time, in accordance with ADB's Anticorruption Policy and Integrity Principles and Guidelines, including declaring ineligible, either indefinitely or for a stated period of time, to participate in ADB-financed, -administered, or -supported activities or to benefit from an ADB-financed, -administered, or -supported contract, financially or otherwise, if it at any time determines that the firm or individual has, directly or through an agent, engaged in corrupt, fraudulent, collusive, coercive, or obstructive practices or other integrity violations; and
 - (e) will have the right to require that a provision be included in bidding documents and in contracts financed, administered, or supported by ADB, requiring Bidders, suppliers and contractors, consultants, manufacturers, service providers and other third parties engaged or involved in ADB-related activities, and their respective officers, directors, employees and personnel, to permit ADB or its representative to inspect the site and their assets, accounts and records and other documents relating to the bid submission and contract performance and to have them audited by auditors appointed by ADB.

- 3.3 All Bidders, consultants, contractors, suppliers, manufacturers, service providers, and other third parties engaged or involved in ADB-related activities and their respective officers, directors, employees and personnel, are obliged to cooperate fully in any investigation when requested by ADB to do so. As determined on a case by case basis by ADB, such cooperation includes, but is not limited to, the following:
- (a) being available to be interviewed and replying fully and truthfully to all questions asked;
 - (b) providing ADB with any items requested that are within the party's control including, but not limited to, documents and other physical objects;
 - (c) upon written request by ADB, authorizing other related entities to release directly to ADB such information that is specifically and materially related, directly or indirectly, to the said entities or issues which are the subject of the investigation;
 - (d) cooperating with all reasonable requests to search or physically inspect their person and/or work areas, including files, electronic databases, and personal property used on ADB activities, or that utilizes ADB's Information and Communication Technology (ICT) resources or systems (including mobile phones, personal electronic devices, and electronic storage devices such as external disk drives);
 - (e) cooperating in any testing requested by ADB, including but not limited to, fingerprint identification, handwriting analysis, and physical examination and analysis; and
 - (f) preserving and protecting confidentiality of all information discussed with, and as required by, ADB.
- 3.4 All Bidders, consultants, contractors and suppliers shall require their officers, directors, employees, personnel, agents to ensure that, in its contracts with its subconsultants, Subcontractors and other third parties engaged or involved in ADB-related activities, such subconsultants, Subcontractors and other third parties similarly are obliged to cooperate fully in any investigation when requested by ADB to do so.
- 3.5 The Supplier shall permit ADB or its representative to inspect the Supplier's site, assets, accounts and records and other documents relating to the bid submission and contract performance of the Supplier and to have them audited by auditors appointed by ADB, if so required by ADB.
- 3.6 The Supplier undertakes that no fees, gratuities, rebates, gifts, commissions or other payments, other than those shown in the bid, have been given or received in connection with the procurement process or in the contract execution.

4. Interpretation

- 4.1 If the context so requires it, singular means plural and vice versa.

4.2 Incoterms

- (g) The meaning of any trade term and the rights and obligations of parties thereunder shall be as prescribed by Incoterms.
- (h) EXW, CIF, CIP, and other similar terms, shall be governed by the rules prescribed in the current edition of Incoterms, published by the International Chamber of Commerce at the date of the Invitation for Bids or as specified in the SCC.

4.3 Entire Agreement

The Contract constitutes the entire agreement between the Purchaser and the Supplier and supersedes all communications, negotiations, and agreements (whether written or oral) of parties with respect thereto made prior to the date of Contract.

4.4 Amendment

No amendment or other variation of the Contract shall be valid unless it is in writing, is dated, expressly refers to the Contract, and is signed by a duly authorized representative of each party thereto.

4.5 Nonwaiver

- (i) Subject to GCC Subclause 4.5(b) below, no relaxation, forbearance, delay, or indulgence by either party in enforcing any of the terms and conditions of the Contract or the granting of time by either party to the other shall prejudice, affect, or restrict the rights of that party under the Contract, neither shall any waiver by either party of any breach of Contract operate as waiver of any subsequent or continuing breach of Contract.
- (j) Any waiver of a party's rights, powers, or remedies under the Contract must be in writing, dated, and signed by an authorized representative of the party granting such waiver, and must specify the right and the extent to which it is being waived.

4.6 Severability

If any provision or condition of the Contract is prohibited or rendered invalid or unenforceable, such prohibition, invalidity, or unenforceability shall not affect the validity or enforceability of any other provisions and conditions of the Contract.

5. Language

- 5.1 The Contract as well as all correspondence and documents relating to the Contract exchanged by the Supplier and the Purchaser, shall be written in the language specified in the SCC. Supporting documents and printed literature that are part of the Contract may be in another language provided they are accompanied by an accurate translation of the relevant passages in the language specified in the SCC, in

which case, for purposes of interpretation of the Contract, this translation shall govern.

5.2 The Supplier shall bear all costs of translation to the governing language and all risks of the accuracy of such translation.

6. Joint Venture 6.1 If the Supplier is a Joint Venture all of the parties shall be jointly and severally liable to the Purchaser for the fulfillment of the provisions of the Contract and shall designate one party to act as a leader with authority to bind the Joint Venture. The composition or the constitution of the Joint Venture shall not be altered without the prior consent of the Purchaser.

7. Eligibility 7.1 The Supplier and its Subcontractors shall have the nationality of an eligible country. A Supplier or Subcontractor shall be deemed to have the nationality of a country if it is a citizen or constituted, incorporated, or registered, and operates in conformity with the provisions of the laws of that country.

7.2 All Goods and Related Services to be supplied under the Contract and financed by ADB shall have their origin in Eligible Countries. For the purpose of this clause, "country of origin" means the country where the goods have been grown, mined, cultivated, produced, manufactured, or processed; or through manufacture, processing, or assembly, another commercially recognized article results that differs substantially in its basic characteristics from its imported components.

8. Notices 8.1 Any Notice given by one party to the other pursuant to the Contract shall be in writing to the address specified in the SCC. The term "in writing" means communicated in written form with proof of receipt.

8.2 A Notice shall be effective when delivered or on the Notice's effective date, whichever is later.

9. Governing Law 9.1 The Contract shall be governed by and interpreted in accordance with the laws of the Purchaser's country, unless otherwise specified in the SCC.

10. Settlement of Disputes 10.1 The Purchaser and the Supplier shall make every effort to resolve amicably by direct informal negotiation any disagreement or dispute arising between them under or in connection with the Contract.

10.2 If the parties fail to resolve such a dispute or difference by mutual consultation within 28 days from the commencement of such consultation, either party may require that the dispute be referred for resolution to the formal mechanisms specified in the SCC.

11. Scope of Supply 11.1 Subject to the SCC, the Goods and Related Services to be supplied shall be as specified in Section 6 (Schedule of Supply).

11.2 Unless otherwise stipulated in the Contract, the Scope of Supply shall include all such items not specifically mentioned in the Contract but that can be reasonably inferred from the Contract as being required

for attaining Delivery and Completion of the Goods and Related Services as if such items were expressly mentioned in the Contract.

- 12. Delivery**
- 12.1 Subject to GCC Subclause 33.1, the Delivery of the Goods and Completion of the Related Services shall be in accordance with the Delivery and Completion Schedule specified in the Section 6 (Schedule of Supply). The details of shipping and other documents to be furnished by the Supplier are specified in the SCC.
- 13. Supplier's Responsibilities**
- 13.1 The Supplier shall supply all the Goods and Related Services included in the Scope of Supply in accordance with GCC Clause 11, and the Delivery and Completion Schedule, as per GCC Clause 12.
- 14. Purchaser's Responsibilities**
- 14.1 Whenever the supply of Goods and Related Services requires that the Supplier obtain permits, approvals, and import and other licenses from local public authorities, the Purchaser shall, if so required by the Supplier, make its best effort to assist the Supplier in complying with such requirements in a timely and expeditious manner.
- 14.2 The Purchaser shall pay all costs involved in the performance of its responsibilities, in accordance with GCC Subclause 14.1.
- 15. Contract Price**
- 15.1 The Contract Price shall be as specified in the Agreement subject to any additions and adjustments thereto, or deductions therefrom, as may be made pursuant to the Contract.
- 15.2 Prices charged by the Supplier for the Goods delivered and the Related Services performed under the Contract shall not vary from the prices quoted by the Supplier in its bid, with the exception of any price adjustments authorized in the SCC.
- 16. Terms of Payment**
- 16.1 The Contract Price shall be paid as specified in the SCC.
- 16.2 The Supplier's request for payment shall be made to the Purchaser in writing, accompanied by invoices describing, as appropriate, the Goods delivered and Related Services performed, and by the documents submitted pursuant to GCC Clause 12 and upon fulfillment of all the obligations stipulated in the Contract.
- 16.3 Payments shall be made promptly by the Purchaser, no later than 60 days after submission of an invoice or request for payment by the Supplier, and the Purchaser has accepted it.
- 16.4 The currency or currencies in which payments shall be made to the Supplier under this Contract shall be specified in the SCC.
- 17. Taxes and Duties**
- 17.1 For goods supplied from outside the Purchaser's country, the Supplier shall be entirely responsible for all taxes, stamp duties, license fees, and other such levies imposed outside the Purchaser's country.

- 17.2 For goods supplied from within the Purchaser's country, the Supplier shall be entirely responsible for all taxes, duties, license fees, etc., incurred until delivery of the contracted Goods to the Purchaser.
- 17.3 If any tax exemptions, reductions, allowances or privileges may be available to the Supplier in the Purchaser's Country, the Purchaser shall use its best efforts to enable the Supplier to benefit from any such tax savings to the maximum allowable extent.
- 18. Performance Security**
- 18.1 The Supplier shall, within 28 days of the notification of Contract award, provide a Performance Security for the due performance of the Contract in the amounts and currencies specified in the SCC.
- 18.2 The proceeds of the Performance Security shall be payable to the Purchaser as compensation for any loss resulting from the Supplier's failure to complete its obligations under the Contract.
- 18.3 The Performance Security shall be denominated in the currencies of the Contract, or in a freely convertible currency acceptable to the Purchaser, and shall be in one of the forms stipulated by the Purchaser in the SCC, or in another form acceptable to the Purchaser.
- 18.4 The Performance Security shall be discharged by the Purchaser and returned to the Supplier not later than 28 days following the date of completion of the Supplier's performance obligations under the Contract, including any warranty obligations, unless specified otherwise in the SCC.
- 19. Copyright**
- 19.1 The copyright in all drawings, documents, and other materials containing data and information furnished to the Purchaser by the Supplier herein shall remain vested in the Supplier, or, if they are furnished to the Purchaser directly or through the Supplier by any third party, including suppliers of materials, the copyright in such materials shall remain vested in such third party.
- 20. Confidential Information**
- 20.1 The Purchaser and the Supplier shall keep confidential and shall not, without the written consent of the other party hereto, divulge to any third party any documents, data, or other information furnished directly or indirectly by the other party hereto in connection with the Contract, whether such information has been furnished prior to, during or following completion or termination of the Contract. Notwithstanding the above, the Supplier may furnish to its Subcontractor such documents, data, and other information it receives from the Purchaser to the extent required for the Subcontractor to perform its work under the Contract, in which event the Supplier shall obtain from such Subcontractor an undertaking of confidentiality similar to that imposed on the Supplier under GCC Clause 20.
- 20.2 The Purchaser shall not use such documents, data, and other information received from the Supplier for any purposes unrelated to the Contract. Similarly, the Supplier shall not use such documents, data, and other information received from the Purchaser for any purpose other than the design, procurement, or other work and services required for the performance of the Contract.

- 20.3 The obligation of a party under GCC Subclauses 20.1 and 20.2 above, however, shall not apply to information that
- (k) the Purchaser or Supplier needs to share with ADB or other institutions participating in the financing of the Contract;
 - (l) now or hereafter enters the public domain through no fault of that party;
 - (m) can be proven to have been possessed by that party at the time of disclosure and which was not previously obtained, directly or indirectly, from the other party; or
 - (n) otherwise lawfully becomes available to that party from a third party that has no obligation of confidentiality.
- 20.4 The above provisions of GCC Clause 20 shall not in any way modify any undertaking of confidentiality given by either of the parties hereto prior to the date of the Contract in respect of the Supply or any part thereof.
- 20.5 The provisions of GCC Clause 20 shall survive completion or termination, for whatever reason, of the Contract.

21. Subcontracting

- 21.1 The Supplier shall notify the Purchaser in writing of all subcontracts awarded under the Contract if not already specified in the Bid. Subcontracting shall in no event relieve the Supplier from any of its obligations, duties, responsibilities, or liability under the Contract.
- 21.2 Subcontracts shall comply with the provisions of GCC Clauses 3 and 7.

22. Specifications and Standards

- 22.1 Technical Specifications and Drawings
- (o) The Supplier shall ensure that the Goods and Related Services comply with the technical specifications and other provisions of the Contract.
 - (p) The Supplier shall be entitled to disclaim responsibility for any design, data, drawing, specification or other document, or any modification thereof provided or designed by or on behalf of the Purchaser, by giving a notice of such disclaimer to the Purchaser.
 - (q) The Goods and Related Services supplied under this Contract shall conform to the standards mentioned in Section 6 (Schedule of Supply) and, when no applicable standard is mentioned, the standard shall be equivalent or superior to the official standards whose application is appropriate to the country of origin of the Goods.

22.2 Wherever references are made in the Contract to codes and standards in accordance with which it shall be executed, the edition or the revised version of such codes and standards shall be those specified in the Section 6 (Schedule of Supply). During Contract execution, any changes in any such codes and standards shall be applied only after approval by the Purchaser and shall be treated in accordance with GCC Clause 33.

23. Packing and Documents

23.1 The Supplier shall provide such packing of the Goods as is required to prevent their damage or deterioration during transit to their final destination, as indicated in the Contract. During transit, the packing shall be sufficient to withstand, without limitation, rough handling and exposure to extreme temperatures, salt and precipitation, and open storage. Packing case size and weights shall take into consideration, where appropriate, the remoteness of the final destination of the Goods and the absence of heavy handling facilities at all points in transit.

23.2 The packing, marking, and documentation within and outside the packages shall comply strictly with such special requirements as shall be expressly provided for in the Contract, including additional requirements, if any, specified in the SCC, and in any other instructions ordered by the Purchaser.

24. Insurance

24.1 Unless otherwise specified in the SCC, the Goods supplied under the Contract shall be fully insured, in a freely convertible currency from an eligible country, against loss or damage incidental to manufacture or acquisition, transportation, storage, and delivery, in accordance with the applicable Incoterms or in the manner specified in the SCC.

25. Transportation

25.1 Unless otherwise specified in the SCC, obligations for transportation of the Goods shall be in accordance with the Incoterms specified in Section 6 (Schedule of Supply).

26. Inspections and Tests

26.1 The Supplier shall at its own expense and at no cost to the Purchaser carry out all such tests and/or inspections of the Goods and Related Services as are specified in Section 6 (Schedule of Supply).

26.2 The inspections and tests may be conducted on the premises of the Supplier or its Subcontractor, at point of delivery, and/or at the final destination of the Goods, or in another place in the Purchaser's country as specified in the SCC. Subject to GCC Subclause 26.3, if conducted on the premises of the Supplier or its Subcontractor, all reasonable facilities and assistance, including access to drawings and production data, shall be furnished to the inspectors at no charge to the Purchaser.

26.3 The Purchaser or its designated representative shall be entitled to attend the tests and/or inspections referred to in GCC Subclause 26.2, provided that the Purchaser bear all of its own costs and expenses incurred in connection with such attendance including, but not limited to, all traveling and board and lodging expenses.

- 26.4 Whenever the Supplier is ready to carry out any such test and inspection, it shall give a reasonable advance notice, including the place and time, to the Purchaser. The Supplier shall obtain from any relevant third party or manufacturer any necessary permission or consent to enable the Purchaser or its designated representative to attend the test and/or inspection.
- 26.5 The Purchaser may require the Supplier to carry out any test and/or inspection not required by the Contract but deemed necessary to verify that the characteristics and performance of the Goods comply with the technical specifications, codes, and standards under the Contract, provided that the Supplier's reasonable costs and expenses incurred in the carrying out of such test and/or inspection shall be added to the Contract Price. Further, if such test and/or inspection impedes the progress of manufacturing and/or the Supplier's performance of its other obligations under the Contract, due allowance will be made in respect of the Delivery Dates and Completion Dates and the other obligations so affected.
- 26.6 The Supplier shall provide the Purchaser with a report of the results of any such test and/or inspection.
- 26.7 The Purchaser may reject any Goods or any part thereof that fail to pass any test and/or inspection or do not conform to the specifications. The Supplier shall either rectify or replace such rejected Goods or parts thereof or make alterations necessary to meet the specifications at no cost to the Purchaser, and shall repeat the test and/or inspection, at no cost to the Purchaser, upon giving a notice pursuant to GCC Subclause 26.4.
- 26.8 The Supplier agrees that neither the execution of a test and/or inspection of the Goods or any part thereof, nor the attendance by the Purchaser or its representative, nor the issue of any report pursuant to GCC Subclause 26.6, shall release the Supplier from any warranties or other obligations under the Contract.
- 27. Liquidated Damages**
- 27.1 Except as provided under GCC Clause 32, if the Supplier fails to deliver any or all of the Goods or perform the Related Services within the period specified in the Contract, the Purchaser may without prejudice to all its other remedies under the Contract, deduct from the Contract Price, as liquidated damages, a sum equivalent to the percentage specified in the SCC of the Contract Price for each week or part thereof of delay until actual delivery or performance, up to a maximum deduction of the percentage specified in the SCC. Once the maximum is reached, the Purchaser may terminate the Contract pursuant to GCC Clause 35.
- 28. Warranty**
- 28.1 The Supplier warrants that all the Goods are new, unused, and of the most recent or current models, and that they incorporate all recent improvements in design and materials, unless provided otherwise in the Contract.
- 28.2 Subject to GCC Subclause 22.1, the Supplier further warrants that the Goods shall be free from defects arising from any act or omission of the Supplier or arising from design, materials, and workmanship,

under normal use in the conditions prevailing in the country of final destination.

- 28.3 Unless otherwise specified in the SCC, the warranty shall remain valid for 12 months after the Goods, or any portion thereof as the case may be, have been delivered to and accepted at the final destination indicated in the SCC, or for 18 months after the date of shipment or loading in the country of origin, whichever period concludes earlier.
- 28.4 The Purchaser shall give Notice to the Supplier, stating the nature of any such defects together with all available evidence thereof, promptly following the discovery thereof. The Purchaser shall afford all reasonable opportunity for the Supplier to inspect such defects.
- 28.5 Upon receipt of such Notice, the Supplier shall, within the period specified in the SCC, expeditiously repair or replace the defective Goods or parts thereof, at no cost to the Purchaser.
- 28.6 If having been notified, the Supplier fails to remedy the defect within the period specified in the SCC, the Purchaser may proceed to take within a reasonable period such remedial action as may be necessary, at the Supplier's risk and expense and without prejudice to any other rights which the Purchaser may have against the Supplier under the Contract.

29. Patent Indemnity

- 29.1 The Supplier shall, subject to the Purchaser's compliance with GCC Subclause 29.2, indemnify and hold harmless the Purchaser and its employees and officers from and against any and all suits, actions or administrative proceedings, claims, demands, losses, damages, costs, and expenses of any nature, including attorney's fees and expenses, which the Purchaser may suffer as a result of any infringement or alleged infringement of any patent, utility model, registered design, trademark, copyright, or other intellectual property right registered or otherwise existing at the date of the Contract by reason of
- (r) the installation of the Goods by the Supplier or the use of the Goods in the country where the Site is located; and
 - (s) the sale in any country of the products produced by the Goods.

Such indemnity shall not cover any use of the Goods or any part thereof other than for the purpose indicated by or to be reasonably inferred from the Contract, neither any infringement resulting from the use of the Goods or any part thereof, or any products produced thereby in association or combination with any other equipment, plant, or materials not supplied by the Supplier, pursuant to the Contract.

- 29.2 If any proceedings are brought or any claim is made against the Purchaser arising out of the matters referred to in GCC Subclause 29.1, the Purchaser shall promptly give the Supplier a notice thereof, and the Supplier may at its own expense and in the Purchaser's name

conduct such proceedings or claim and any negotiations for the settlement of any such proceedings or claim.

- 29.3 If the Supplier fails to notify the Purchaser within 28 days after receipt of such notice that it intends to conduct any such proceedings or claim, then the Purchaser shall be free to conduct the same on its own behalf.
- 29.4 The Purchaser shall, at the Supplier's request, afford all available assistance to the Supplier in conducting such proceedings or claim, and shall be reimbursed by the Supplier for all reasonable expenses incurred in so doing.
- 29.5 The Purchaser shall indemnify and hold harmless the Supplier and its employees, officers, and Subcontractors from and against any and all suits, actions or administrative proceedings, claims, demands, losses, damages, costs, and expenses of any nature, including attorney's fees and expenses, which the Supplier may suffer as a result of any infringement or alleged infringement of any patent, utility model, registered design, trademark, copyright, or other intellectual property right registered or otherwise existing at the date of the Contract arising out of or in connection with any design, data, drawing, specification, or other documents or materials provided or designed by or on behalf of the Purchaser.

30. Limitation of Liability

- 30.1 Except in cases of gross negligence or willful misconduct,
- (t) neither party shall be liable to the other party for any indirect or consequential loss or damage, loss of use, loss of production, or loss of profits or interest costs, provided that this exclusion shall not apply to any obligation of the Supplier to pay liquidated damages to the Purchaser; and
 - (u) the aggregate liability of the Supplier to the Purchaser, whether under the Contract, in tort, or otherwise, shall not exceed the amount specified in the SCC, provided that this limitation shall not apply to the cost of repairing or replacing defective equipment, or to any obligation of the Supplier to indemnify the Purchaser with respect to patent infringement.

31. Change in Laws and Regulations

- 31.1 Unless otherwise specified in the Contract, if after the date of the Invitation for Bids, any law, regulation, ordinance, order or bylaw having the force of law is enacted, promulgated, abrogated, or changed in the place of the Purchaser's country where the Site is located (which shall be deemed to include any change in interpretation or application by the competent authorities) that subsequently affects the Delivery Date and/or the Contract Price, then such Delivery Date and/or Contract Price shall be correspondingly increased or decreased, to the extent that the Supplier has thereby been affected in the performance of any of its obligations under the Contract. Notwithstanding the foregoing, such additional or reduced cost shall not be separately paid or credited if the same has already been accounted for in the price

adjustment provisions where applicable, in accordance with GCC Clause 15.

32. Force Majeure

32.1 The Supplier shall not be liable for forfeiture of its Performance Security, liquidated damages, or termination for default if and to the extent that its delay in performance or other failure to perform its obligations under the Contract is the result of an event of Force Majeure.

32.2 For purposes of this clause, "Force Majeure" means an event or situation beyond the control of the Supplier that is not foreseeable, is unavoidable, and its origin is not due to negligence or lack of care on the part of the Supplier. Such events may include, but not be limited to, acts of the Purchaser in its sovereign capacity, wars or revolutions, fires, floods, epidemics, quarantine restrictions, and freight embargoes.

32.3 If a Force Majeure situation arises, the Supplier shall promptly notify the Purchaser in writing of such condition and the cause thereof. Unless otherwise directed by the Purchaser in writing, the Supplier shall continue to perform its obligations under the Contract as far as is reasonably practical, and shall seek all reasonable alternative means for performance not prevented by the Force Majeure event.

33. Change Orders and Contract Amendments

33.1 The Purchaser may at any time order the Supplier through Notice in accordance GCC Clause 8, to make changes within the general scope of the Contract in any one or more of the following:

- (v) drawings, designs, or specifications, where Goods to be furnished under the Contract are to be specifically manufactured for the Purchaser;
- (w) the method of shipment or packing;
- (x) the place of delivery; and
- (y) the Related Services to be provided by the Supplier.

33.2 If any such change causes an increase or decrease in the cost of, or the time required for, the Supplier's performance of any provisions under the Contract, an equitable adjustment shall be made in the Contract Price or in the Delivery and Completion Schedule, or both, and the Contract shall accordingly be amended. Any claims by the Supplier for adjustment under this Clause must be asserted within 28 days from the date of the Supplier's receipt of the Purchaser's change order.

33.3 Prices to be charged by the Supplier for any Related Services that might be needed but which were not included in the Contract shall be agreed upon in advance by the parties and shall not exceed the prevailing rates charged to other parties by the Supplier for similar services.

34. Extensions of Time

- 34.1 If at any time during performance of the Contract, the Supplier or its Subcontractors should encounter conditions impeding timely delivery of the Goods or completion of Related Services pursuant to GCC Clause 12, the Supplier shall promptly notify the Purchaser in writing of the delay, its likely duration, and its cause. As soon as practicable after receipt of the Supplier's notice, the Purchaser shall evaluate the situation and may at its discretion extend the Supplier's time for performance, in which case the extension shall be ratified by the parties by amendment of the Contract.
- 34.2 Except in case of Force Majeure, as provided under GCC Clause 32, a delay by the Supplier in the performance of its Delivery and Completion obligations shall render the Supplier liable to the imposition of liquidated damages pursuant to GCC Clause 27, unless an extension of time is agreed upon, pursuant to GCC Subclause 34.1.

35. Termination

35.1 Termination for Default

- (z) The Purchaser, without prejudice to any other remedy for breach of Contract, by Notice of default sent to the Supplier, may terminate the Contract in whole or in part,
- (aa) (i) if the Supplier fails to deliver any or all of the Goods within the period specified in the Contract, or within any extension thereof granted by the Purchaser pursuant to GCC Clause 34; or
 - (bb) (ii) if the Supplier fails to perform any other obligation under the Contract.
 - (cc) (iii) if the Supplier, in the judgment of the Purchaser has engaged in integrity violations, as defined in GCC Clause 3, in competing for or in executing the Contract.
- (dd) In the event the Purchaser terminates the Contract in whole or in part, pursuant to GCC Clause 35.1(a), the Purchaser may procure, upon such terms and in such manner as it deems appropriate, Goods or Related Services similar to those undelivered or not performed, and the Supplier shall be liable to the Purchaser for any additional costs for such similar Goods or Related Services. However, the Supplier shall continue performance of the Contract to the extent not terminated.

35.2 Termination for Insolvency

- (ee) The Purchaser may at any time terminate the Contract by giving Notice to the Supplier if the Supplier becomes bankrupt or otherwise insolvent. In such event, termination will be without compensation to the Supplier, provided that such termination will not prejudice or affect any right of action or remedy that has accrued or will accrue thereafter to the Purchaser.

35.3 Termination for Convenience

- (ff) The Purchaser, by Notice sent to the Supplier, may terminate the Contract, in whole or in part, at any time for its convenience. The Notice of termination shall specify that termination is for the Purchaser's convenience, the extent to which performance of the Supplier under the Contract is terminated, and the date upon which such termination becomes effective.
- (gg) The Goods that are complete and ready for shipment within 28 days after the Supplier's receipt of the Notice of termination shall be accepted by the Purchaser at the Contract terms and prices. For the remaining Goods, the Purchaser may elect
 - (i) to have any portion completed and delivered at the Contract terms and prices; and/or
 - (ii) to cancel the remainder and pay to the Supplier an agreed amount for partially completed Goods and Related Services and for materials and parts previously procured by the Supplier.

36. Assignment

- 36.1 Neither the Purchaser nor the Supplier shall assign, in whole or in part, their obligations under this Contract, except with prior written consent of the other party.

37. Respectful Work Environment

- 37.1 The Contractor shall ensure that its employees and Subcontractors observe the highest ethical standards and refrain from any form of bullying, discrimination, misconduct and harassment, including sexual harassment and shall, at all times, behave in a manner that creates an environment free of unethical behavior, bullying, misconduct and harassment, including sexual harassment. The Contractor shall take appropriate action against any employees or Subcontractors, including suspension or termination of employment or sub-contract, if any form of unethical or inappropriate behavior is identified.
- 37.2 The Contractor shall conduct training programs for its employees and Subcontractors to raise awareness on and prevent any form of bullying, discrimination, misconduct, and harassment including sexual harassment, and to promote a respectful work environment. The Contractor shall keep an up to date record of its employees and subcontractors who have attended and completed such training programs and provide such records to the Purchaser at their first written request.

Section 8: Special Conditions of Contract

The following Special Conditions of Contract (SCC) shall supplement the General Conditions of Contract (GCC). Whenever there is a conflict, the provisions herein shall prevail over those in the GCC.

GCC 1.1(j)	The Purchaser's country is: Bhutan
GCC 1.1(k)	The Purchaser is: Ministry of Education and Skills Development (MoESD)
GCC 1.1 (q)	The Site is: Technical Training Institute Thimphu.
GCC 4.2 (b)	The version of Incoterms shall be: 2020
GCC 5.1	The language shall be: English The language for translation of supporting documents and printed literature is: English
GCC 8.1	For notices , the Purchaser's address shall be: Attention: Project Director, PMU, STEPUP, DWPSD, MoESD Street address: Thimphu Country: Bhutan Telephone: 02335923 E-mail: nwangchuk@moesd.gov.bt
GCC 9.1	The governing law shall be: Law of Kingdom of Bhutan
GCC 10.2	The formal mechanism for the resolution of disputes shall be: Arbitration <u>For a contract with a Foreign Supplier:</u> Arbitration Rules of the Singapore International Arbitration Centre Place of arbitration: Singapore <u>For a contract with a Local Supplier:</u> Bhutan Alternative Dispute Resolution Center (BADRC) Place of arbitration: Thimphu
GCC 11.1	The Scope of Supply shall be defined in: Procurement of Automobile Tools and Equipment (Lot 1-8)
GCC 12.1	Details of shipping and documents to be furnished by the Supplier shall be: For Goods from outside the Purchaser's country:

Bidding Document for G-13 Procurement of Automobile Tools and Equipment (Lot 1-8)

	<p>Upon shipment, the Supplier shall notify the Purchaser and the Insurance Company in writing the full details of the shipment, including Contract number, description of Goods, quantity, the vessel, the bill of lading number and date, port of loading, date of shipment, port of discharge, etc. The Supplier shall send the following documents to the Purchaser, with a copy to the Insurance Company:</p> <ul style="list-style-type: none"> a) Two copies of the Supplier's invoice showing the description of the Goods, quantity, unit price, and total amount; b) Negotiable, clean, on-board bill of lading/lorry receipt marked "freight/charges prepaid" and two copies of non-negotiable bill of lading/lorry receipt; c) Three copies of the packing list identifying contents of each package; d) insurance certificate; e) Manufacturer's or Supplier's warranty certificate; f) Certificate of origin <p>The Purchaser shall receive the above documents at least 1 week before arrival of the Goods at the port or place of arrival and, if not received, the Supplier will be responsible for any consequent expenses.</p> <p>For Goods from within the Purchaser's country: Upon delivery of the Goods to the transporter, the Supplier shall notify the Purchaser and send the following documents to the Purchaser:</p> <ul style="list-style-type: none"> a) A copy of the Supplier's invoice showing the description of the Goods, quantity, unit price, and total amount; b) Delivery note, railway receipt, or truck receipt; c) Manufacturer's or Supplier's warranty certificate; d) Certificate of origin. <p>The Purchaser shall receive the above documents before the arrival of the Goods and, if not received, the Supplier will be responsible for any consequent expenses.</p>
GCC 15.2	The price adjustment shall be: NA

GCC 16.1	<p>Payment of the Contract Price shall be made in the following manner:</p> <p>For Goods and Related Services supplied from outside the Purchaser's country:</p> <p>a) Advance Payment: If the bidders require advance payment (optional), 10% of the Contract Price within 28 days of signing of the Contract may be paid to the supplier. However, the payment shall be made provided the Supplier presents a request for payment accompanied by an Advance Payment Security (unconditional bank guarantee) in the form of a bank guarantee for an amount equal to the amount of payment, and that shall be valid until the Goods are delivered. The security shall be in the form as specified in Section 9 (Contract Forms).</p> <p>b) On Shipment: The Purchaser shall pay the Supplier 80% of the Contract Price of the Goods shipped through telegraphic transfer in Ngultrum, upon submission of documents specified in SCC Clause 12.1.</p> <p>c) On Acceptance: 10% of the Contract Price of Goods received shall be paid within 28 days of receipt of the Goods upon submission of a claim supported by the acceptance certificate issued by the Purchaser.</p> <p>For Goods and Related Services supplied from within the Purchaser's country:</p> <p>a) Advance Payment: 10% of the Contract Price within 28 days of signing of the Contract. Payment shall be made provided the Supplier presents a request for payment accompanied by an Advance Payment Security (unconditional bank guarantee) in the form of a bank guarantee for an amount equal to the amount of the payment, and that shall be valid until the Goods are delivered. The security shall be in the form as specified in Section 9 (Contract Forms).</p> <p>b) On Delivery: The Purchaser shall pay the Supplier 80% of the Contract Price of the Goods shipped through telegraphic transfer in Ngultrum, upon submission of documents specified in SCC Clause 12.1.</p> <p>c) On Acceptance: 10% of the Contract Price of Goods received shall be paid within 28 days of receipt of the Goods upon submission of a claim supported by the acceptance certificate issued by the Purchaser.</p>
GCC 16.4	The currencies for payments shall be: Ngultrum
GCC 18.1	The Supplier shall provide a Performance Security of 10% percent of the Contract Price. The Performance Security shall be denominated in the following amounts and currencies: Ngultrum

GCC 18.3	The forms of acceptable Performance Security are: A bank guarantee issued by a reputable bank located in the Purchaser's country, acceptable to the Purchaser, in the format included in Section 9 (Contract Forms).
GCC 18.4	Discharge of the Performance Security shall take place: (a) In accordance with GCC Sub clause 18.4. The performance security shall be reduced to 5% of the contract price upon acceptance of the delivered goods to cover the warranty obligation in accordance with GCC clause 28.3.

<p>GCC 23.2</p>	<p>The packing, marking, and documentation within and outside the packages shall be:</p> <p>Packing:</p> <p>The supplied Goods shall be packed by standard protective measures. Such packing shall be suitable for long distance transportation and well protected against dampness, moisture, shock, rust and rough handling so as to ensure that the Goods will safely arrive at the designated site without any damage due to the abovementioned reasons, and</p> <p>In each package there shall be one copy each of the detailed packing list and the quality certificate.</p> <p>Marking:</p> <p>(1) The Supplier shall mark the following on the four adjacent sides of each package with indelible paint in conspicuous English printed words:</p> <ul style="list-style-type: none"> a. consignee b. contract no. c. shipping mark d. consignee code e. destination f. name of goods and item no., case no. <p>When several items in one case, there will be insufficient area on the packing case side to provide this information. In this case, place a copy of detailed packing list in a waterproof envelope on the outside of the case. The envelope outside must provide details of the items inside the box/case.</p> <ul style="list-style-type: none"> g. gross/net weight (kg) h. measurement (length x width x height in cm) <p>(2) If any package weighs two (2) metric tons or more, the Supplier shall mark on two sides of each package in English and with appropriate transportation marks to show the "center of gravity" and "points of slinging" in order to facilitate loading, discharging and handling. According to the characteristics of the Goods and the different requirements in transportation, packages shall be marked legibly by the Supplier with words "Handle with Care", "Right Side Up", "Keep Dry", etc., and with other appropriate marks.</p>
<p>GCC 24.1</p>	<p>The insurance coverage shall be in accordance with:</p> <p>Pursuant to GCC, Sub clause 24.1, the Supplier must insure the Goods in an amount equal to 110% of the DPU (Delivery at Place Unloaded), including War Risks and Strikes.</p>

GCC 25.1	Obligations for transportation of the Goods shall be in accordance with: Incoterms 2020, DPU to the place specified in Section 6- Schedule of Supply (Delivery and Completion Schedule)
GCC 26.2	<p>Tests and Inspections specified in Section 6 (Schedule of Supply), shall be carried out at the following times or milestones, and places:</p> <p>At Final Destination as specified in Section 6 Schedule of supply (delivery and completion schedule).</p> <p>The supplier shall provide guarantee/ warranty certificate that the goods conforms to all specifications contained in the contract.</p> <p>All the goods will be inspected on arrival to the destination by the goods receiving committee to check if the supplied goods are as per the technical specification and the samples submitted. If the goods are not as specified in the contract terms and conditions, the goods shall not be accepted. The supplier shall take immediate steps to remedy the deficiency or replace the goods as per the technical specification within the initial delivery period. Following are details for the inspection:</p> <p>Goods: All the goods supplied as per the DS (Delivery Schedule) & PS (Price Schedule)</p> <p>Type of test: To check if the goods supplied are as per the technical specification.</p> <p>Time: when the goods are delivered as per the supply order and delivery schedule,</p> <p>Place: As indicated in the delivery schedule</p>
GCC 27.1	The applicable rate for liquidated damages for delay shall be: 0.5% per week of the undelivered portion.
GCC 27.1	The maximum amount of liquidated damages shall be: 10% of the contract price of the undelivered items.
GCC 28.3	<p>The period of validity of the Warranty shall be: 2 (two) years from the date of delivery and acceptance.</p> <p>The place of final destination shall be: Technical Training Institute Thimphu (Serbithang).</p>
GCC 28.5	The Supplier shall correct any defects covered by the Warranty within 30 days of being notified by the Purchaser of the occurrence of such defects.
GCC 30.1 (b)	The amount of aggregate liability shall be: 100% of the Contract Price

Section 9: Contract Forms

Table of Forms

Notice of Intention for Award of Contract	9-2
Notification of Award	9-3
Contract Agreement	9-4
Performance Security	9-6
Advance Payment Security	9-7

Notice of Intention for Award of Contract

[on letterhead paper of the Purchaser]

[date of notification]

To: [name of the Bidder]
 Attention: [insert name of the Bidder's authorized representative]
 Address: [insert address of the Bidder's authorized representative]
 Telephone/Fax numbers: [insert telephone/fax numbers of the Bidder's authorized representative]
 E-mail Address: [insert e-mail address of the Bidder's authorized representative]

This is to notify you of our intention to award the contract [insert name of the contract and identification number, as given in the Bid Data Sheet]. You have [insert number of days as specified in ITB 40.1 of the BDS] days from the date of this notification to (i) request for a debriefing in relation to the evaluation of your Bid; and/or (ii) submit a bidding-related complaint in relation to the intention for award of contract, in accordance with the procedures specified in ITB 46.1.

The summary of the evaluation are as follows:

1. List of Bidders

Name of Bidder	Bid Price as Read Out at Opening	Evaluated Bid Price

2. Reason/s Why Your Bid Was Unsuccessful

.....

3. The Successful Bidder

Name of Bidder:	
Address:	
Contract Price:	
Duration of Contract:	
Scope of the Contract Awarded:	
Amount Performance Security Required:	

Authorized Signature:

Name and Title of Signatory:

Name of Agency:

Notification of Award

[on letterhead of the Purchaser]

Letter of Acceptance

[date]

To: [name and address of the supplier]

Subject: Contract No. [please specify]

This is to notify you that your Bid dated [date] for execution of the [name of the contract and identification number, as given in the Bid Data Sheet] for the Accepted Contract Amount of the equivalent of [amount in words and figures and name of currency], as corrected and modified in accordance with the Instructions to Bidders is hereby accepted by our Agency.

You are requested to furnish the Performance Security within 28 days in accordance with the Conditions of Contract and any additional security required as a result of the evaluation of your bid, using for that purpose the Performance Security Form included in Section 9 (Contract Forms) of the Bidding Document.

Authorized Signature:

Name and Title of Signatory:

Name of Agency:

Attachment: Contract Agreement

Contract Agreement

THIS AGREEMENT made on the *[insert date]* day of *[insert month]*, *[insert year]*, between *[insert complete name of the purchaser]* of *[insert complete address of the Purchaser]* (hereinafter “the Purchaser”), of the one part, and *[insert complete name of the supplier]* of *[insert complete address of the supplier]* (hereinafter “the Supplier”), of the other part:

WHEREAS the Purchaser invited Bids for certain Goods and Related Services, viz., *[insert brief description of the goods and related services]* and has accepted a Bid by the Supplier for the supply of those Goods and Related Services in the sum of *[insert currency or currencies and amount of contract price in words and figures]* (hereinafter “the Contract Price”).

NOW THIS AGREEMENT WITNESSETH AS FOLLOWS:

1. In this Agreement, words and expressions shall have the same meanings as are respectively assigned to them in the Contract referred to.
2. The following documents shall be deemed to form and be read and construed as part of this Agreement, viz.:
 - (a) Letter of Acceptance;
 - (b) Bid Submission Sheet and the Price Schedules submitted by the Supplier;
 - (c) Addenda Nos. *[insert addenda numbers if any]*⁵
 - (d) Special Conditions of Contract;
 - (e) List of Eligible Countries that was specified in Section 5 of the Bidding Document;
 - (f) General Conditions of Contract;
 - (g) Schedule of Supply; and
 - (h) any other documents shall be added here.

This Contract shall prevail over all other Contract documents. In the event of any discrepancy or inconsistency within the Contract documents, then the documents shall prevail in the order listed above.

3. In consideration of the payments to be made by the Purchaser to the Supplier as indicated in this Agreement, the Supplier hereby covenants with the Purchaser to provide the Goods and Related Services and to remedy defects therein in conformity in all respects with the provisions of the Contract.
4. The Purchaser hereby covenants to pay the Supplier in consideration of the provision of the Goods and Related Services and the remedying of defects therein, the Contract Price or such other sum as may become payable under the provisions of the Contract at the times and in the manner prescribed by the Contract.

IN WITNESS whereof the parties hereto have caused this Agreement to be executed in accordance with the laws of *[indicated name of country]* on the day, month, and year indicated above.

⁵ Information contained in the addenda and or addendum should preferably be included in the contract documents to avoid potential ambiguities during contract implementation. If however, unavoidable priority should be decided depending on the nature of information provided in the addenda/addendum.

Signed by *[insert authorized signature for the Purchaser]* (for the Purchaser)

Signed by *[insert authorized signature for the supplier]* (for the Supplier)

Performance Security

[Bank's name, and address of issuing branch or office]

Beneficiary: [Name and address of the Purchaser]

Date: [Insert date (as day, month, and year)]

Performance Guarantee No.:

We have been informed that [name of the supplier] (hereinafter called "the Supplier") has entered into Contract No. [reference number of the contract] dated [date] with you, for the execution of [name of contract and brief description of goods and related services] (hereinafter called "the Contract").

Furthermore, we understand that, according to the conditions of the Contract, a performance guarantee is required.

At the request of the Supplier, we [name of the bank] hereby irrevocably undertake to pay you any sum or sums not exceeding in total an amount of [name of the currency and amount in words]⁶ [amount in figures] such sum being payable in the types and proportions of currencies in which the Contract Price is payable, upon receipt by us of your first demand in writing accompanied by a written statement stating that the Supplier is in breach of its obligation(s) under the Contract, without your needing to prove or to show grounds for your demand or the sum specified therein.

This guarantee shall expire, no later than the [date] day of [month], [year],⁷ and any demand for payment under it must be received by us at this office on or before that date.

This guarantee is subject to the Uniform Rules for Demand Guarantees (URDG) 2010 Revisions, ICC Publication No. 758, except that the supporting statement under Article 15(a) is hereby excluded⁸

.....
[Signature(s) and seal of bank (where appropriate)]

-- Note to Bidder --

If the bank issuing performance security is located outside the Purchaser's country, it shall be counter-guaranteed or encashable by a bank in the Purchaser's country.

⁶ The guarantor shall insert an amount representing the percentage of the contract price specified in the contract and denominated either in the currency(ies) of the contract or in any freely convertible currency acceptable to the Purchaser.

⁷ Insert the date 28 days after the expected completion date. The Purchaser should note that in the event of an extension of the time for completion of the contract, the Purchaser would need to request an extension of this guarantee from the guarantor. Such request must be in writing and must be made prior to the expiration date established in the guarantee. In preparing this guarantee, the Purchaser might consider adding the following text to the form, at the end of the penultimate paragraph: "The Guarantor agrees to a one-time extension of this guarantee for a period not to exceed [six months] [one year], in response to the Purchaser's written request for such extension, such request to be presented to the Guarantor before the expiry of the guarantee."

⁸ Or the purchaser may use "Uniform Rules for Demand Guarantees (URDG), ICC Publication No. 458, except that subparagraph (ii) of Sub-article 20(a) is hereby excluded" as appropriate.

Advance Payment Security

[insert complete name and number of contract]

To: *[insert complete name of the Purchaser]*

In accordance with the payment provision included in the Contract, in relation to advance payments, *[insert complete name of the supplier]* (hereinafter called “the Supplier”) shall deposit with the Purchaser a security consisting of *[indicate type of security]*, to guarantee its proper and faithful performance of the obligations imposed by said Clause of the Contract, in the amount of *[insert currency and amount of guarantee in words and figures]*.

We, the undersigned *[insert complete name of the guarantor]*, legally domiciled in *[insert full address of the guarantor]* (hereinafter “the Guarantor”), as instructed by the Supplier, agree unconditionally and irrevocably to guarantee as primary obligor and not as surety merely, the payment to the Purchaser on its first demand without whatsoever right of objection on our part and without its first claim to the Supplier, in the amount not exceeding *[insert currency and amount of guarantee in words and figures]*.

This security shall remain valid and in full effect from the date of the advance payment being received by the Supplier under the Contract until *[insert date (as day, month, year)]*.

This guarantee is subject to the Uniform Rules for Demand Guarantees (URDG) 2010 Revisions, ICC Publication No. 758, except that the supporting statement under Article 15(a) is hereby excluded.¹

Name: *[insert complete name of person signing the Security]*

In the capacity of *[insert legal capacity of person signing the Security]*

Signed: *[insert signature of person whose name and capacity are shown above]*

Duly authorized to sign the security for and on behalf of *[insert seal (where appropriate) and complete name of the guarantor]*

Date: *[insert date of signing]*

-- Note to Bidder --

If the bank issuing advance payment security is located outside the Purchaser's country, it shall be counter-guaranteed or encashable by a bank in the Purchaser's country.

¹ Or the purchaser may use “Uniform Rules for Demand Guarantees (URDG), ICC Publication No. 458, except that subparagraph (ii) of Sub-article 20(a) is hereby excluded” as appropriate.